

# research report

## **Residential Hip Roof Framing Using Cold-Formed Steel Members**

**RESEARCH REPORT RP06-2**

**2006**



**American Iron and Steel Institute**



**Steel Framing Alliance™**

*Steel. The Better Builder.*

**DISCLAIMER**

The material contained herein has been developed by researchers based on their research findings and is for general information only. The information in it should not be used without first securing competent advice with respect to its suitability for any given application. The publication of the information is not intended as a representation or warranty on the part of the American Iron and Steel Institute, Steel Framing Alliance, or of any other person named herein, that the information is suitable for any general or particular use or of freedom from infringement of any patent or patents. Anyone making use of the information assumes all liability arising from such use.

## **PREFACE**

The objectives of this project were to investigate a more rational rafter design methodology for both gable and hip roofs and develop all the necessary tables, details and specification requirements for hip roof framing members and connections for addition to the *AISI Standard for Cold-Formed Steel framing – Prescriptive Method for One and Two Family Dwellings [Prescriptive Method]*. This report accomplishes these objectives, provides useful insight and suggests future study topics that should assist in identifying and prioritizing future research needs.

It is expected that portions of this report will indeed be incorporated in the *Prescriptive Method*. As such, the results of this work will have a lasting and beneficial impact on the steel-framed residential construction industry.

Research Team  
Steel Framing Alliance

**Final Report**

**RESIDENTIAL HIP ROOF FRAMING USING COLD-FORMED STEEL  
MEMBERS**

**by**

**Luke Waldo  
Research Assistant**

**Sutton F. Stephens  
Roger A. LaBoube  
Project Directors**

**A Research Project Sponsored by the  
American Iron and Steel Institute**

**July, 2006**

**Department of Civil Engineering  
Wei-Wen Yu Center for Cold-Formed Steel Structures  
University of Missouri-Rolla  
Rolla, Missouri**

## TABLE OF CONTENTS

	Page
<b>PREFACE</b>	<b>4</b>
<b>1.0 Analysis of Hip Roof System</b>	<b>6</b>
<b>1.1 Analysis Procedure</b>	<b>6</b>
<b>1.1.1 Model Development</b>	<b>6</b>
<b>1.1.2 Results of RISA-3D Analysis</b>	<b>10</b>
<b>1.2 Comparison of Unsheathed and Sheathed Roof Framing Systems</b>	<b>12</b>
<b>1.2.1 Analysis Summary and Comparison</b>	<b>12</b>
<b>1.3 Conclusions</b>	<b>12</b>
<b>1.4 Recommendations for Further Research</b>	<b>13</b>
<b>2.0 Hip Framing Analysis and Design</b>	<b>26</b>
<b>2.1 General</b>	<b>26</b>
<b>2.2 Loads</b>	<b>26</b>
<b>2.2.1 Dead Loads (D)</b>	<b>27</b>
<b>2.2.2 Roof Live Load (<math>L_r</math>)</b>	<b>27</b>
<b>2.2.3 Roof Snow Load (S)</b>	<b>27</b>
<b>2.2.4 Wind Load (W)</b>	<b>27</b>
<b>2.3 Load Combinations</b>	<b>28</b>
<b>2.4 Hip Member Analysis and Design</b>	<b>29</b>
<b>2.5 Hip Member Support Column</b>	<b>29</b>
<b>2.5.1 Column Above Ceiling</b>	<b>30</b>
<b>2.5.2 Column Support Below Ceiling</b>	<b>31</b>

<b>2.6 Connections</b>	<b>31</b>
<b>2.6.1 Hip Member Connection at Ridge</b>	<b>32</b>
<b>2.6.2 Hip Member Connection at Wall Corner</b>	<b>33</b>
<b>2.6.3 Hip Support Column Connection at the Ceiling</b>	<b>33</b>
<b>2.7 Alternate Hip and Ridge Member Configuration</b>	<b>34</b>
<b>2.8 Conclusions</b>	<b>35</b>
<b>APPENDIX A – DESIGN CALCULATIONS</b>	<b>44</b>

## PREFACE

Cold-formed steel is continuing to increase in popularity in the residential construction market and is gaining an increasing market share compared with other construction materials. Conventionally framed roof construction uses rafters, ridge members, and ceiling joists and does not include any supplemental interior ridge member supports or collar ties between rafters although ceiling joists may be supported by an interior bearing wall. At hip ends, conventionally framed construction uses hip members and jack rafters, and ridge member support braces are also commonly used. Section R802.3 of the International Residential Code (ICC 2003) states “Hip and valley rafters shall be supported at the ridge by a brace to a bearing partition or be designed to carry and distribute the specific load at that point.” Conventional framing has traditionally been used in light framed wood structures and more recently in roofs framed with cold-formed steel members.

The American Iron and Steel Institute developed the *Standard for Cold-Formed Steel Framing – Prescriptive Method for One and Two Family Dwellings* (AISI 2002). This Standard is useful for the design of residential projects because it allows standard one and two story residential structures to be designed without the services of an architect or structural engineer. The current edition of the *Prescriptive Method*, however, does not address the design of the members necessary to construct hip roofs. Accordingly, the AISI Committee on Framing Standards (COFS) determined that research should be carried out to develop all the information necessary to allow for the construction of hip roofs using the *Prescriptive Method*. One of the objectives of this study was to investigate a more rational rafter design methodology for both gable and hip roofs. A second objective was to develop all the necessary tables, details and specification requirements for additions to the *Prescriptive Method*, and the *Commentary to the Prescriptive Method* for hip roof framing members and connections.

This report is based mainly on a thesis submitted to the Faculty of the Graduate School of the Kansas State University in partial fulfillment of the requirements for the degree of Masters of Science in Architectural Engineering.

Technical guidance for this study was provided by the Steel Framing Alliance's Project Monitoring Task Group (Bill Babich, Nader Elhajj, Steve Fox, Dick Layding, and Steve Walker), and the American Iron and Steel Institute's Prescriptive Method Subcommittee (Steve Fox, Chairperson). The Project Monitoring Task Group and the Subcommittee's guidance is gratefully acknowledged. Appreciation is also extended to Jay Larson, AISI for his guidance and assistance. Partial funding for this study was provided by the American Iron and Steel Institutes. The authors extend their appreciation to AISI for the financial support.



## **1.0 Analysis of Hip Roof System**

### **1.1 Analysis Procedure**

The purpose of this portion of the report is to provide details of a finite element analysis that was conducted to investigate the interaction of plywood sheathing with a typical rafter. The goal was to determine what contribution the sheathing makes in the distribution of forces to other members in the framing system. The current method of analysis for conventionally framed roof rafters, whether of wood or cold-formed steel, is to ignore compressive forces and design the rafter for bending only (AFPA 2001a, AISI 2003). Rafters are designed as individual pieces, neglecting any strength and stiffness contribution of the sheathing other than to provide restraint against lateral-torsional buckling. However, a simple two dimensional analysis of the rafter in combination with the ceiling joist and the rafter on the opposite side of the ridge to form a truss type framing system, as show in Figure 1.2, shows that a compression force is developed in the rafters. It should also be noted that the lower the slope of the rafter, the greater the axial compression in the rafters.

An unsupported hip roof system does not provide direct support, via either columns or bracing, for the hip and ridge members. Because of this, the structural support for these members is provided by the rafters that frame into them, the ridge member being supported by the side rafters, and the hip rafters being supported by the jack rafters.

#### **1.1.1 Model Development**

Computer models of two different sloped hip roofs were developed for analysis utilizing RISA-3D (RISA 2005) analysis and design software. Both sheathed and unsheathed models were built. All hip roof systems were analyzed assuming a 32 ft. x 60 ft. rectangular building with a 2 ft. roof overhang around the perimeter of the roof (Figures 1.1 and 1.2). The horizontal rafter span was 16 ft. from the centerline of the ridge to the outside face of the wall. The rafters were spaced at 24-

inches on center, the most common spacing for roof rafters. The ceiling joists were also spaced at 24-inches and were pinned to the rafter at the top of the wall. Roof slopes of 3:12 and 10:12 were analyzed. A 3:12 roof slope is the minimum allowed when using the *Prescriptive Method* (AISI 2003) and 12:12 is the greatest slope allowed. The 10:12 slope model was selected for analysis since it was assumed to be more common for high sloped roofs.

All members were modeled with simple pin-pin connections. The hip members and ridge members were modeled as a built-up section consisting of a C-shape and a track section (Figure 1.3). The hip members and ridge were assumed continuous for their full length. The ceiling joists were supported at mid-span by an interior bearing wall and were assumed continuous over the interior support. Table 1.1 lists the different member sizes used for analysis of all roof models. The member designations used in the table are in accordance with the *Standard for Cold-Formed Steel Framing – General Provisions* (AISI, 2004).

The perimeter walls were assumed to provide vertical support for gravity load from the roof rafters and ceiling joists. They also were assumed to have sufficient in-plane stiffness to provide lateral restraint for the roof and ceiling members in the plane of the wall. The walls were not assumed to provide any lateral support in the out-of-plane direction at the top of the wall for the roof and ceiling framing members. The wall itself was not included in the model for analysis; however, the continuous top track of the wall was included in the model (Figure 1.4). This member provided a tie in what would be the plane of the wall, just as in an actual structure.

The loading applied to all roof framing models were dead and snow loads. The dead loads applied were those currently assumed in the *Prescriptive Method* and taken from Table A1-1. The *Prescriptive Method* can be used for snow loads up to 70 psf ground snow load. For this study, a 30 psf ground snow load was assumed since it represents a practical maximum for many portions of the

United States. Wind loads were not considered for this study. Figure 1.5 shows the method used for load application to the rafters. A description of the loads used for this study is given as follows:

Roof Dead Load	7 psf
Ceiling Dead Load	5 psf
Ground Snow Load	30 psf (21 psf roof snow load on the projected area)

#### **1.1.1.1 Unsheathed Model**

The first set of models with 3:12, and 10:12 roof slopes, were analyzed without including structural sheathing. As previously stated, it is common practice to neglect any contribution of roof sheathing when designing the framing members except to prevent lateral-torsional buckling of the rafter. This is usually done to simplify analysis and design and is assumed not to add undue conservatism.

#### **1.1.1.2 Sheathed Model**

The *Prescriptive Method* requires the use of wood structural panel for roof sheathing applied directly to the top of the rafters. Wood structural panel sheathing was modeled as plate elements in RISA3D. The individual plate elements were applied as ½-inch thick 4 ft. by 8 ft. sheets which is the actual size of panels used for roof sheathing. It was assumed the sheathing layout would begin at the eaves, with the long direction of the sheet perpendicular to the rafters and continue along the slope up to the ridge. The properties of the structural panel sheathing used in the model are given in Table 1.2. The attachment of the sheathing was assumed to be in accordance with Table F2-10 in the *Prescriptive Method*.

The 4 x 8 foot rectangular plate elements were initially sub-meshed into 2 ft. x 1 ft. rectangular sub-plate elements but then later reduced to 1 ft. x 1 ft. sub-plate elements. After analyzing a number of models, it was determined that by using 1 ft. square sub-plate elements, some

of the inconsistencies experienced with the larger mesh were reduced. The areas at the hips were completed with triangular and non-regular quadrilateral plates as shown in Figure 1.6.

The sub-plate elements themselves were attached at their corners. They were connected to provide continuity, thereby transferring all shear forces, axial forces, and bending moments between adjacent sub-plate elements. The sub-plate elements were directly attached to the rafters, and were considered to be attached at the mid-height centerline of the rafters. This prevented any unintentional composite action between the sheathing and the rafters in bending, even though the sub-plate elements were also connected to provide continuity at all joints along the rafters. The connections to the hip and ridge members, however, did require a different approach.

It was determined the plate elements could not be attached directly to the hip members or the ridge member because RISA-3D was treating the connection between the plate elements on either side of the ridge or hip as fixed. This configuration caused the rafters to act as if they were continuous over the support and thereby producing moment in the rafter at the supports. The solution to this problem was to use very short but very stiff beams to connect the plate element to the hip members and ridge at the same locations where the rafters also connected to the hip and ridge members. These stiff beams were connected to the plate elements to provide continuity, while being pin connected to the hip or ridge members. This configuration approximated a pinned connection from the plate to the hip or ridge, allowing a transfer of shear and axial force without producing moment in the rafter. These additional stiff beam members were 0.02 ft. long (RISA-3D's smallest increment of noticeable change between nodes), and connected in-plane with the plate elements (Figure 1.7). This was done to prevent coplanar errors within the solution. Figure 1.8 shows the final model of the 1 x 1 foot plate mesh layout.

## **1.1.2 Results of RISA-3D Analysis**

The primary focus of this study was to assess the effect sheathing has on forces for typical rafters. A typical rafter in these models is defined as one which frames into the ridge member on one end and is supported at the other on one of the 60-foot long walls. This rafter in combination with the ceiling joist and the rafter on the opposite side of the ridge form a truss type framing system as shown in Figure 1.2. Forces in the typical rafter include axial compression, bending and shear. The hip members are supported at the building corners and span to the ridge at 45 degrees to the typical rafters. The hip members support the jack rafters both along the end and the side walls.

### **1.1.2.1 Unsheathed Model Results**

The results from the 3:12 and 10:12 unsheathed models are summarized in Table 1.3 and provide axial force and bending moments for six of the typical hip roof framing members as shown in Figures 1.9.and 1.10.

#### **1.1.2.1.1 3:12 Model**

For this roof slope, there were significant axial forces developed within all structural members investigated. The typical rafter M42 had an axial compression force of 2.60 kips at 1.9 feet from the cantilevered (lower) end. Its maximum moment was 31.99 kip-inches at 10.63 feet from the cantilevered end. The axial compressive force to be used for design is at the section of maximum moment. Because the maximum axial force in the member decreases from the wall support to the ridge connection, the maximum moment does not occur at the same cross-section as the maximum axial force. The axial compression force at the point of maximum moment was 2.43 kips. The hip member had significant bending of 192.48 kip-inches combined with an axial compressive force of 6.62 kips.

#### **1.1.2.1.2 10:12 Model**

The 10:12 model results also showed significant axial force present in all structural members investigated. As expected, the axial force present in the typical rafter was reduced by more than 40% from 2.60 kips to 1.57 kips due to the increase in slope. The hip had significant bending moment combined with axial compression but these forces were reduced by about 25% in bending and over 50% in axial compression from the 3:12 model. The typical rafter, M113, had a maximum axial compression of 1.56 kips at 2.7 ft. past the cantilevered end. The maximum moment was 33.71 kip-inches at 13.42 ft. from the cantilevered end, with a concurrent axial force of 1.10 kips. The typical hip member, M35, had a bending moment of 147.18 kip-inches at 17.2 ft. from its cantilevered end, with an axial force of 1.93 kips.

#### **1.1.2.2 Sheathed Model Results**

The results from the 3:12 and 10:12 sheathed models are summarized in Table 1.4 and provide axial force and bending data for six of the typical framing members shown in Figures 1.11 and 1.12. The typical rafter was of primary concern in this analysis; however other members are included to show the effect sheathing has on the entire roof system.

##### **1.1.2.2.1 3:12 Model**

For this roof slope, bending moments in the rafters (typical and jack) were essentially unchanged from the unsheathed models, however, axial compression was significantly reduced. Member forces are shown in Table 1.4. The maximum moment in the hip members was only about 7 kip-inches combined with an axial compression force of 2.5 kip.

##### **1.1.2.2.2 10:12 Model**

Similar to the unsheathed model, moment in the rafters did not change appreciably between the 3:12 and 10:12 models; however, axial compression was reduced significantly as expected. For the hip member both moment and axial compression was reduced by well over 50%.

## **1.2 Comparison of Unsheathed and Sheathed Roof Framing Systems**

### **1.2.1 Analysis Summary and Comparison**

Table 1.5 summarizes the results between the sheathed and unsheathed models. The results indicate the inclusion of sheathing greatly reduces the axial compression in the typical rafters. Including the sheathing in the analysis also significantly reduces bending moment in the hip and ridge members, while also reducing the axial compression.

Comparison of the unsheathed and sheathed roof systems shows that the roof system acts more as a stiffened shell, rather than as individual members acting independently. Rafters and the hip members share the axial forces with the sheathing. In general, the sheathing acts to distribute axial forces more evenly between the rafters and hip members. Both roof slopes showed over 50% reduction in axial compression in the side rafters at the point of maximum bending due to the contribution of the structural sheathing. There was also a 35-40% reduction in the maximum axial compression in the side rafters. Figures 1.13 through 1.16 are provided as a graphical representation of the relative axial force and moment distributions for the 3:12 slope model for both the unsheathed and sheathed conditions. There is no correlation of relative magnitude between figures, only between members of each figure.

### **1.3 Conclusions**

It is apparent from the results of this preliminary study there is an interaction between the wood structural panel sheathing and the cold-formed steel framing members of the hip roof system. Through the inclusion of sheathing in the analysis of the roof framing system, axial forces are distributed between the sheathing, rafters and hip members. The result is a lower axial force present in the rafters and lower axial and bending forces in the hip members. The main advantage for considering sheathing to act together with the framing members is that the rafters and hip members

can be designed as much smaller members, thereby reducing the cost of construction. Current design methodologies for both wood and cold-formed steel roofs framed with rafters do not consider any contribution of the roof sheathing. These roofs are shown to be typically unconservative when a rational analysis approach is used. Since current design methodologies are simplified and unconservative, it is apparent that in reality, the sheathing is acting with the framing members to provide the additional margin of safety and prevent a wide spread failures of this type of roof framing system.

#### **1.4 Recommendations for Further Research**

Based on the conclusions drawn from the results of this study, it is apparent the sheathing in conventionally framed roof systems works in conjunction with the rafters as a structural system to resist applied loads. The results indicate that the sheathing has the effect of reducing axial forces in rafters and hip members. Further investigation is required to fully quantify the contribution and of the sheathing and derive a design methodology that accurately models the system behavior and can be easily used for design. Items for further research should include:

- Additional analysis for models with different roof slopes, building widths and load combinations. This is needed to develop a clearer understanding of force distribution and the effect of different slopes, spans and loads on force distribution.
- Develop models for gable roofs to determine if the sheathing provides the same advantage as it appears to for hip roofs.
- Determine connection requirements between the wood structural panel sheathing and the cold-formed steel rafters.
- Determine minimum wood structural panel sheathing material properties required.



- Develop the design methodology that correctly predicts the behavior of the sheathing and the cold-formed steel members for the hip roof framing system. The design methodology should cover design of the sheathing, rafters, hip members, ridge member and connections between the sheathing and supporting members.

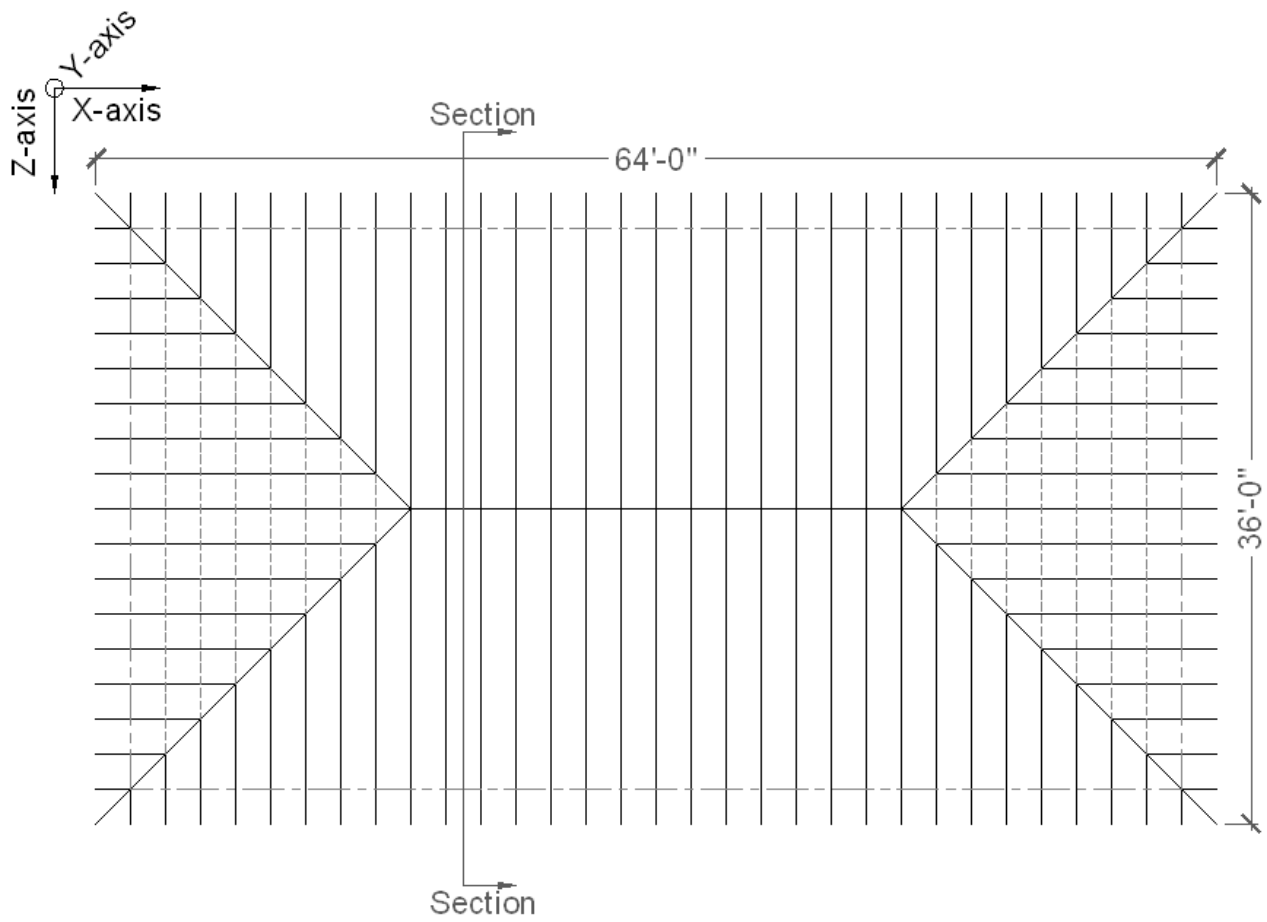

Figure 1.1: Study model roof framing plan

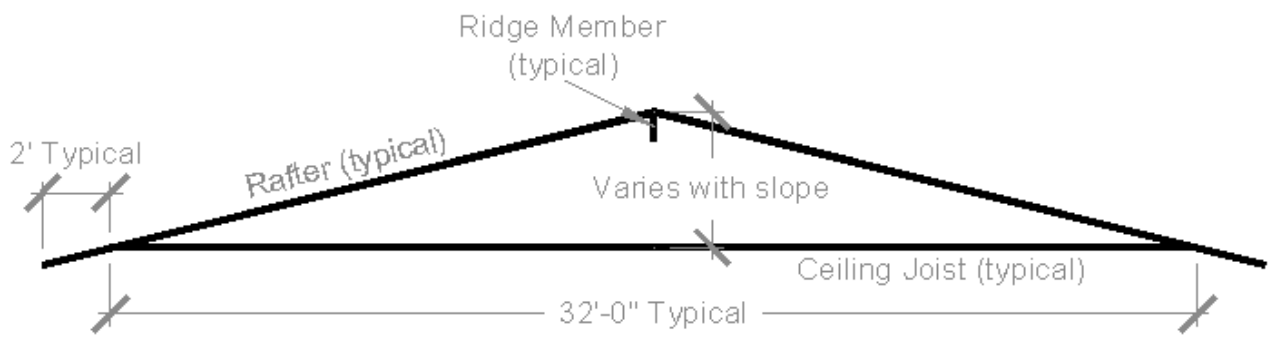

Figure 1.2: Section through roof of study model



Figure 1.3: Typical hip and ridge member configuration

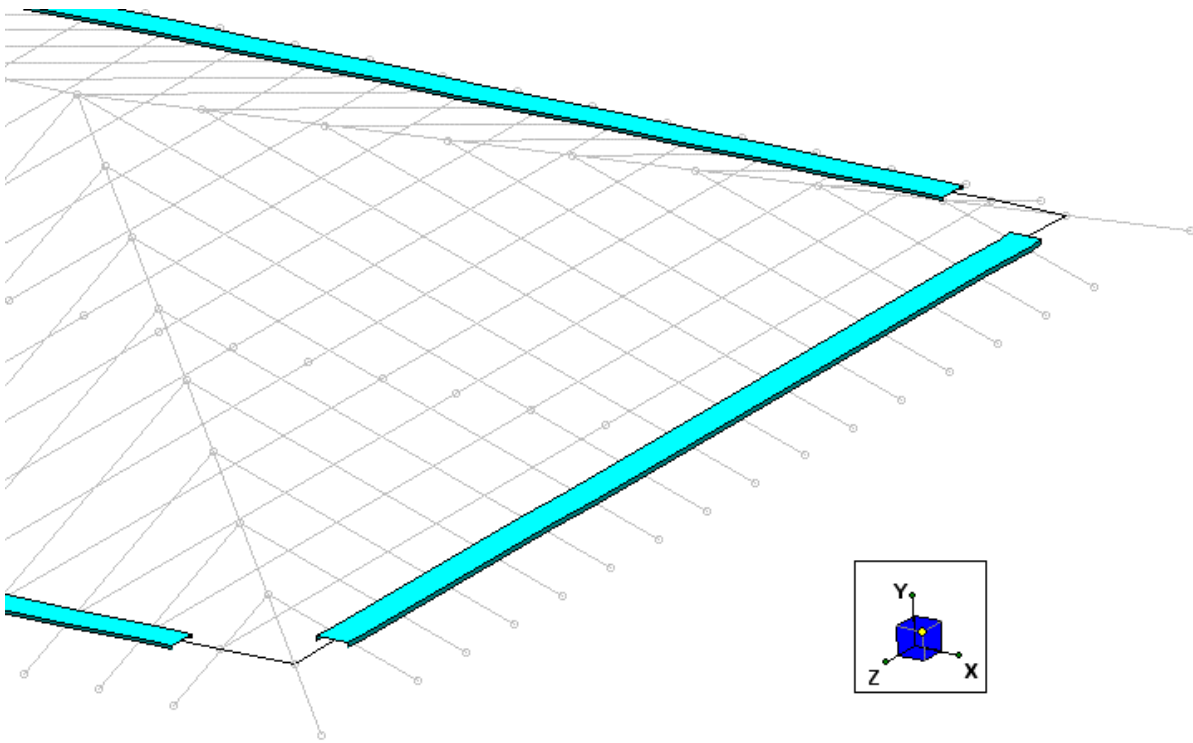

Figure 1.4: Configuration of wall track for computer model

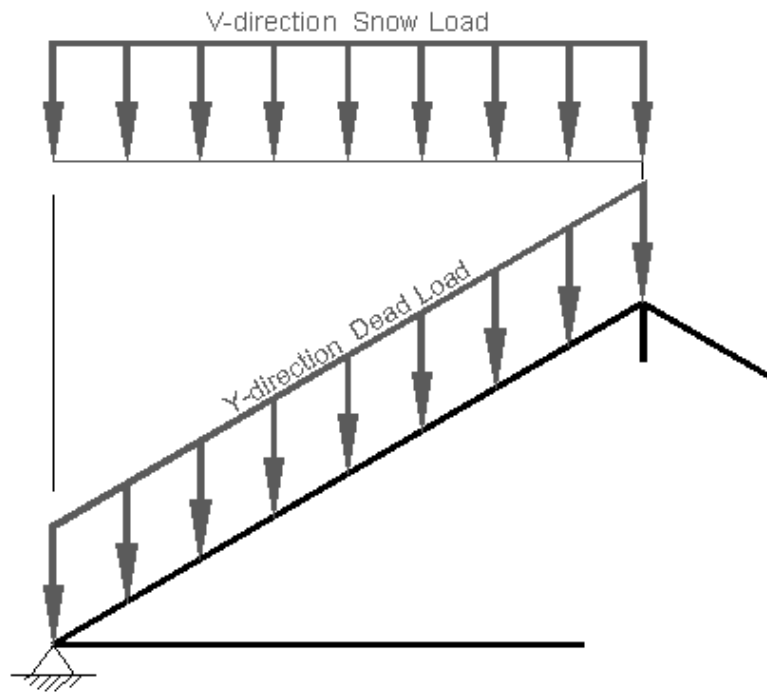

Figure 1.5: Dead and snow load application on rafters

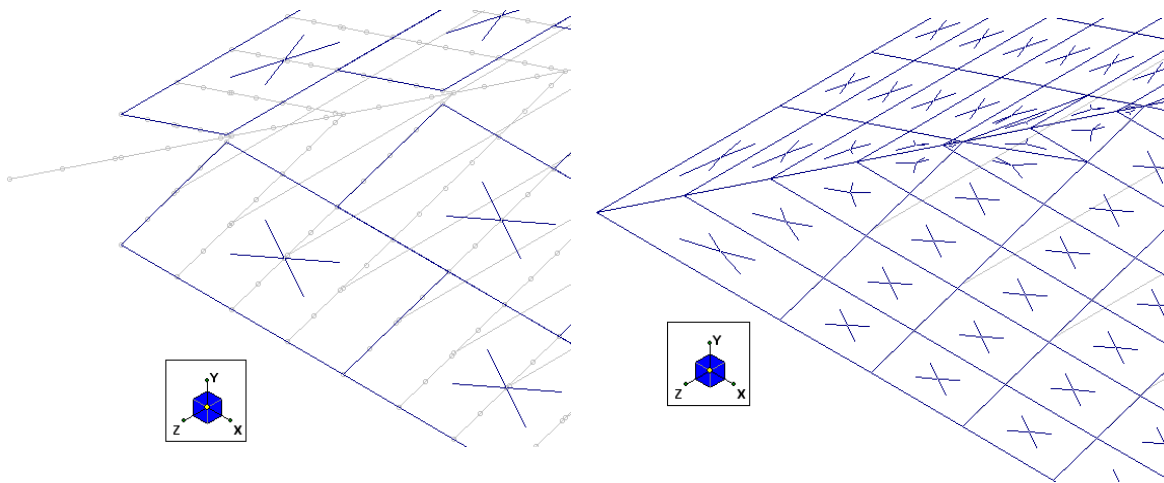

Figure1.6: Sub-meshing at the hips for the sheathed model

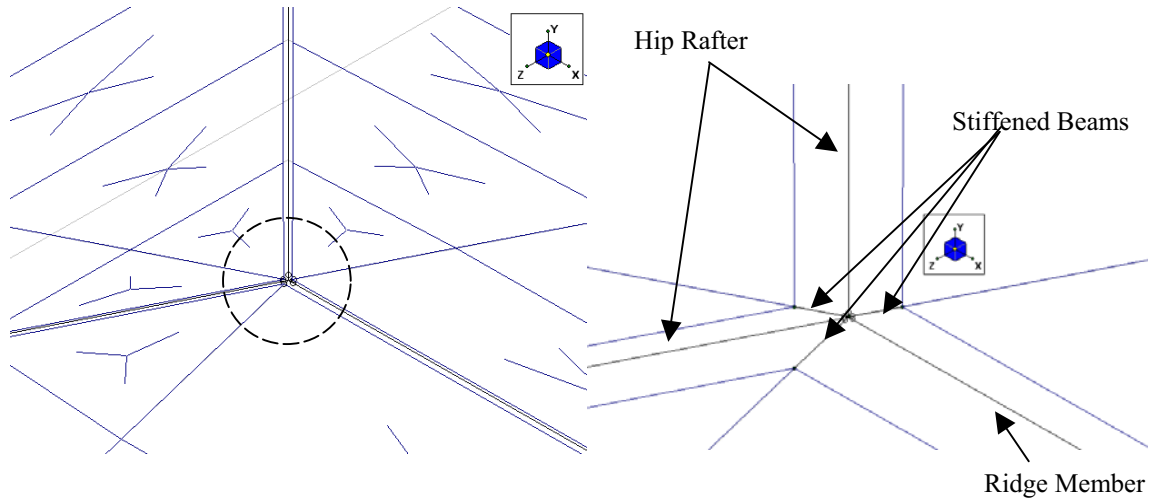

Figure 1.7: Detail of rigid link connection between plates and members

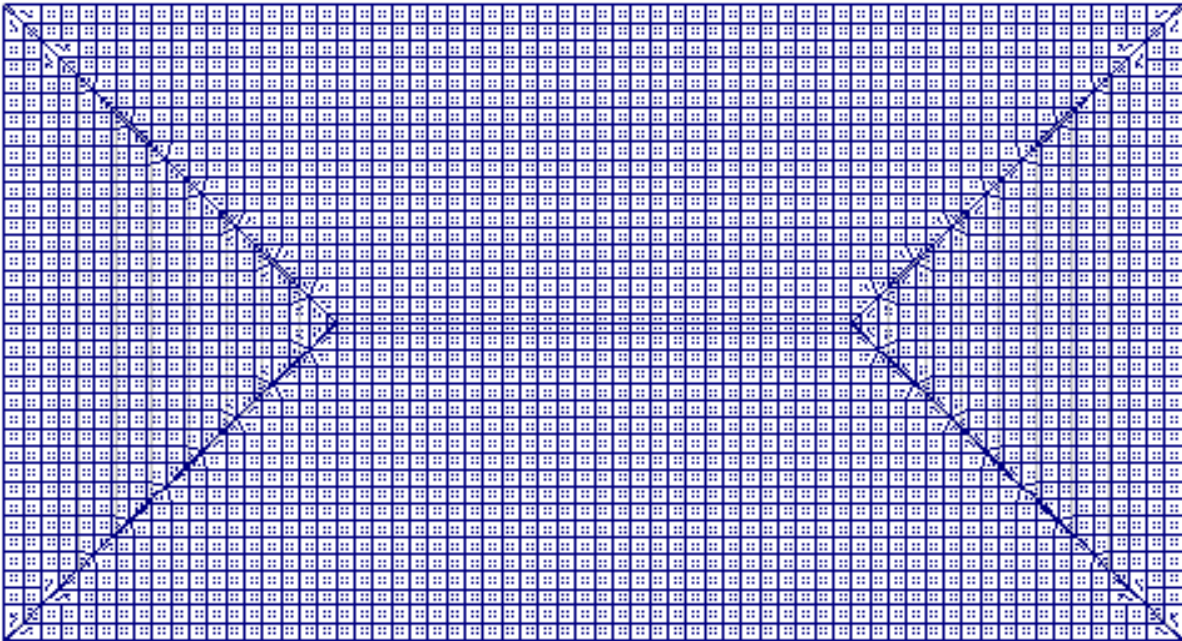

Figure 1.8: Plan view of final sub-meshed hip roof model

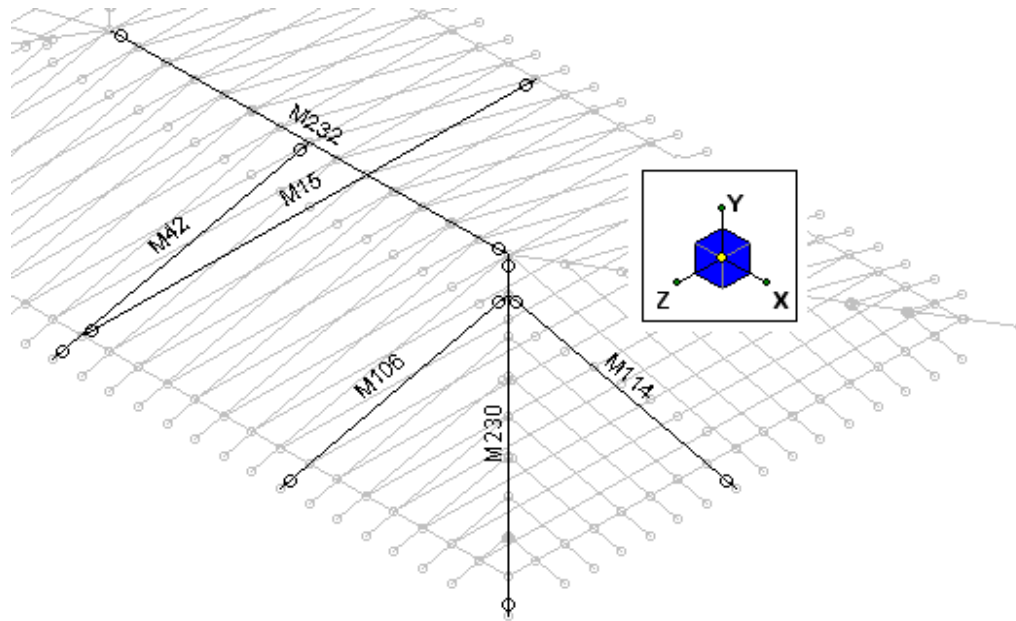

Figure 1.9: Unsheathed 3:12 members used for analysis

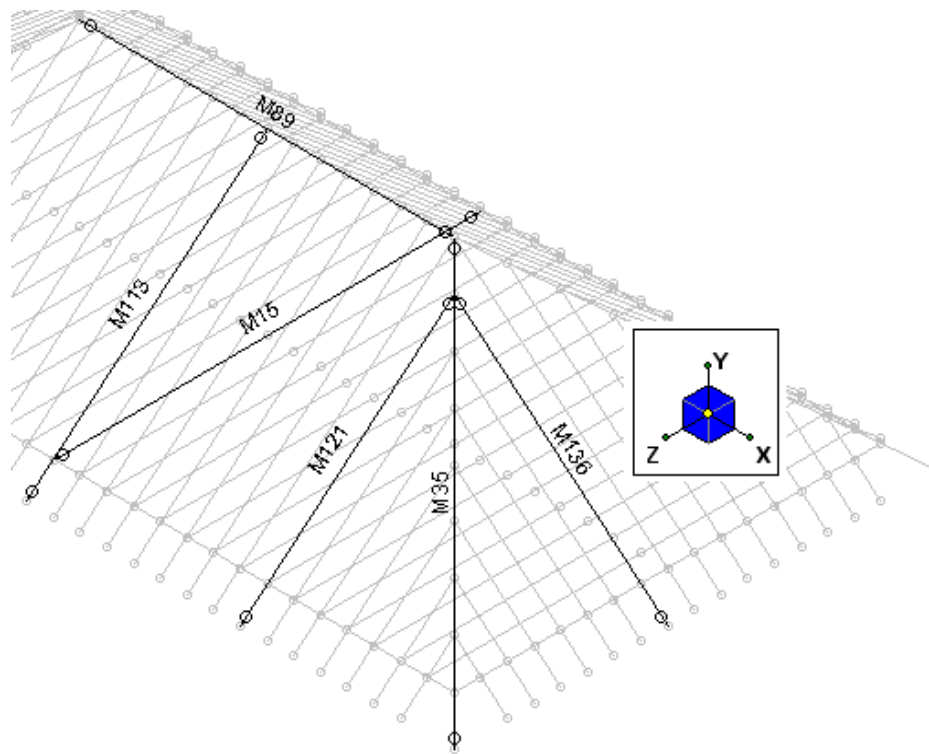

Figure 1.10: Unsheathed 10:12 members used for analysis

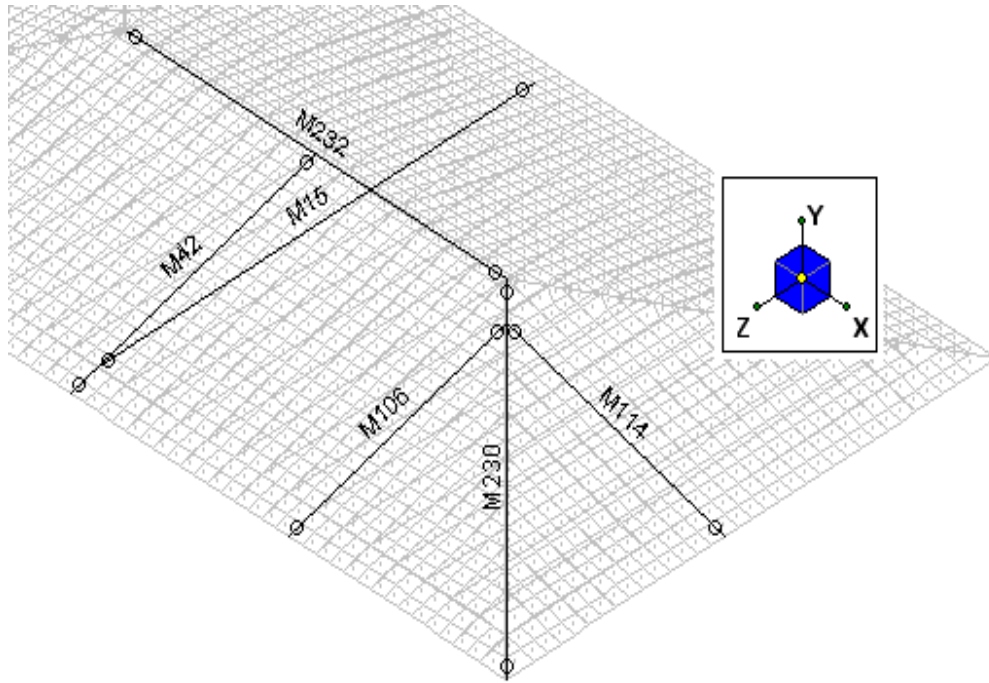

Figure 1.11: Sheathed 3:12 members used for analysis

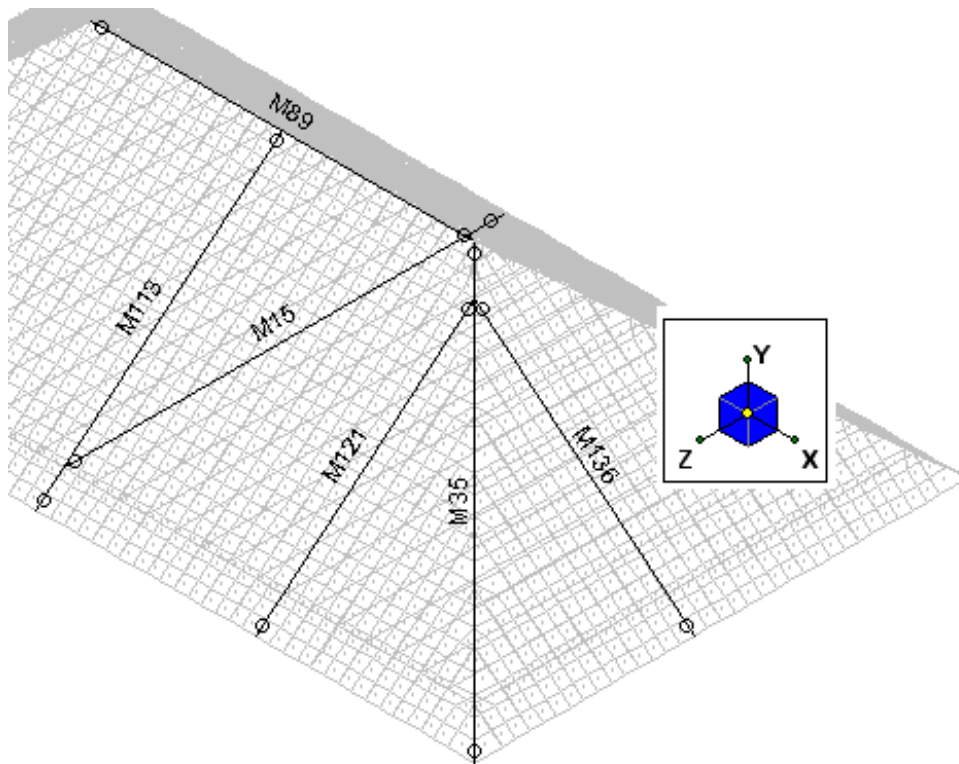

Figure 1.12: Sheathed 10:12 members used for analysis

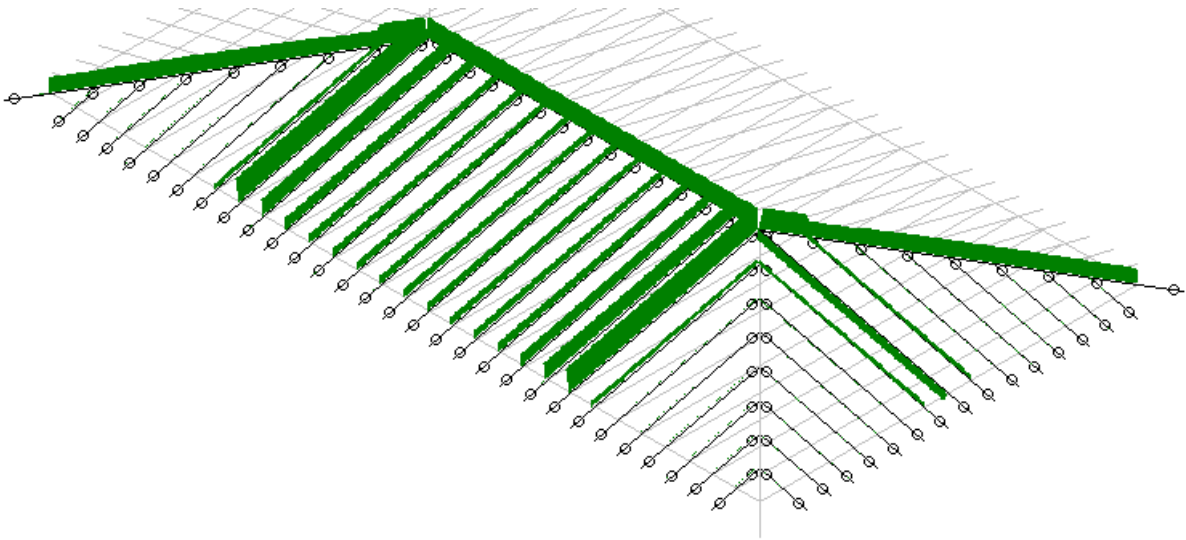

Figure 1.13: 3:12 Unsheathed axial force distribution

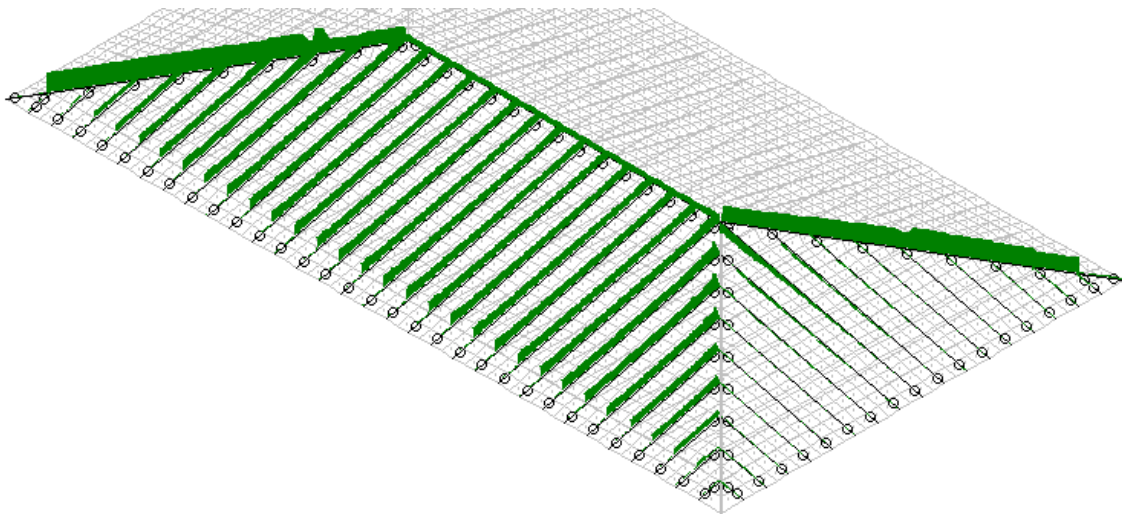

Figure 1.14: 3:12 Sheathed axial force distribution



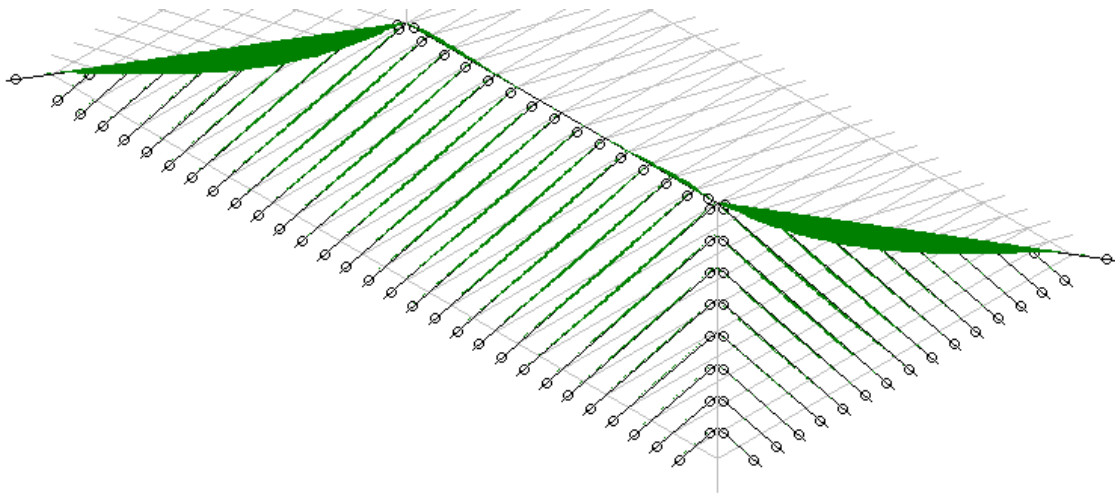

Figure 1.15: 3:12 unsheathed bending moment distribution

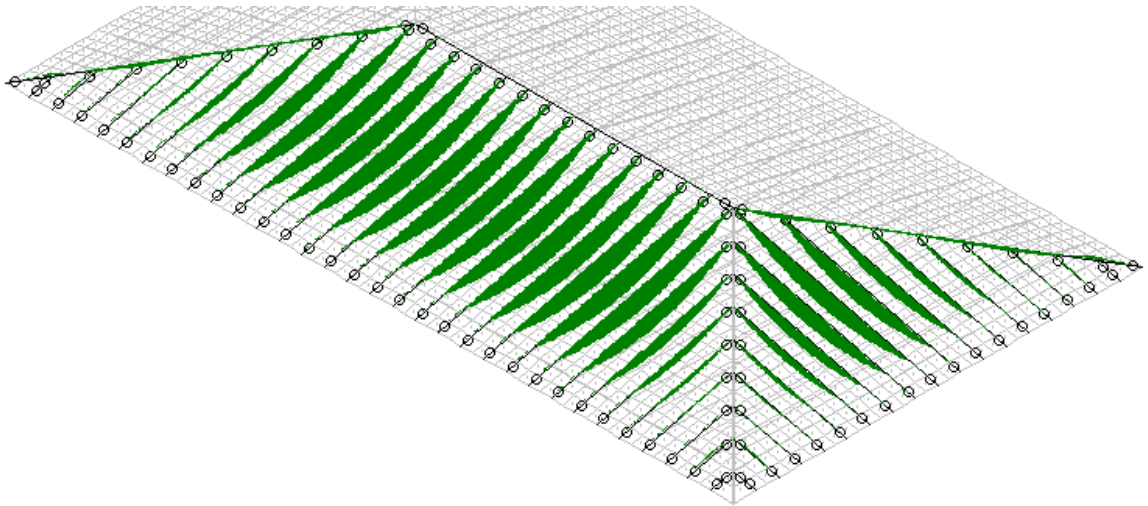

Figure 1.16: 3:12 sheathed bending moment distribution

Table 1.1: Typical member sizes

<b>Member Location</b>	<b>Member Size</b>
Rafters	1000S162-43
Hip/Ridge Members	1000S162-43 and 1000T150-43
Ceiling Joists	550S162-68
Wall Tracks	350T125-33

Table 1.2: Summary of sheathing properties

<b>Property</b>	<b>Value</b>
E (ksi)	1800
G (ksi)	700
Nu	0.15
Density (pcf)	35

Table 1.3: Analysis results for 3:12 roof models

Member Type	3:12 Roof Slope: Unsheathed						
	Member #	Max Moment		Axial Force at Max Moment		Max Axial Force	
		kip-inches	kNm	kips	kN	kips	kN
Typical Rafter	M42	31.99	3.61	2.43	10.81	2.60	11.57
Jack Rafter (side)	M106	23.79	2.69	1.65	7.33	1.79	7.97
Jack Rafter (end)	M114	26.50	2.99	1.53	6.80	1.69	7.52
Hip	M230	192.48	21.75	6.62	29.43	8.08	35.94
Ridge	M232	34.76	3.93	9.10	40.45	9.10	40.46
Ceiling Joist	M15	-4.61	-0.52	-2.36	-10.50	-2.36	-10.50
Member Type	3:12 Roof Slope: Sheathed						
	Member #	Max Moment		Axial Force at Max Moment		Max Axial Force	
		kip-inches	kNm	kips	kN	kips	kN
Typical Rafter	M42	31.41	3.55	1.17	5.20	1.68	7.45
Jack Rafter (side)	M106	23.83	2.69	1.25	5.55	2.32	10.33
Jack Rafter (end)	M114	23.84	2.69	-0.33	-1.46	-0.49	-2.18
Hip	M230	5.58	0.63	2.94	13.06	2.94	13.06
Ridge	M232	1.07	0.12	1.05	4.68	1.20	5.36
Ceiling Joist	M15	-4.61	-0.52	-2.76	-12.28	-2.76	-12.28

Table 1.4: Analysis results for 10:12 roof models

Member Type	10:12 Roof Slope: Unsheathed						
	Member #	Max Moment		Axial Force at Max Moment		Max Axial Force	
		kip-inches	kNm	kips	kN	kips	kN
Typical Rafter	M113	33.71	3.81	1.10	4.88	1.57	6.97
Jack Rafter (side)	M121	25.16	2.84	2.39	10.61	2.80	12.44
Jack Rafter (end)	M136	27.92	3.15	2.74	12.18	3.19	14.18
Hip	M35	147.18	16.63	1.93	8.56	4.79	21.31
Ridge	M89	7.79	0.88	2.22	9.88	2.22	9.88
Ceiling Joist	M15	-4.61	-0.52	-0.84	-3.75	-0.84	-3.75
Member Type	10:12 Roof Slope: Sheathed						
	Member #	Max Moment		Axial Force at Max Moment		Max Axial Force	
		kip-inches	kNm	kips	kN	kips	kN
Typical Rafter	M113	33.45	3.78	0.47	2.09	0.89	3.96
Jack Rafter (side)	M121	25.51	2.88	0.51	2.26	0.82	3.63
Jack Rafter (end)	M136	24.75	2.80	-0.04	-0.18	0.23	1.02
Hip	M35	1.90	0.21	0.53	2.36	1.17	5.19
Ridge	M89	0.20	0.02	0.27	1.21	0.28	1.25
Ceiling Joist	M15	-4.61	-0.52	-0.85	-3.79	-0.85	-3.79

Table 1.5: Comparison of results between sheathed and unsheathed models

Member Type	3:12 Roof Slope			10:12 Roof Slope		
	% Reduction (moment)	% Reduction (axial at moment)	% Reduction (axial at max)	% Reduction (moment)	% Reduction (axial at moment)	% Reduction (axial at max)
Typical Rafter	1.81%	51.95%	35.56%	0.77%	57.25%	43.14%
Jack Rafter (side)	-0.17%	24.33%	-29.63%	-1.41%	78.75%	70.83%
Jack Rafter (end)	10.03%	<i>121.53%</i>	<i>129.05%</i>	11.37%	<i>101.50%</i>	92.79%
Hip	97.10%	55.61%	63.66%	98.71%	72.47%	75.66%
Ridge	96.93%	88.43%	86.76%	97.45%	87.75%	87.39%
Ceiling Joist	0.00%	-16.99%	-16.99%	0.00%	-0.95%	-0.95%

*Italics* : Member switched from maximum compressive value to maximum tension value

## 2.0 Hip Framing Analysis and Design

### 2.1 General

Hip members provide support for jack rafters and span from the building corners to the ridge. They are orientated at 45-degrees to the building walls as shown in Figure 2.1. The hip members are assumed to be single span members with pinned ends. Based on the findings described in Section 1, the hip member for an unsupported hip roof framing system will have considerable bending moment combined with a very significant axial compressive force. Additionally, the rafters that frame into the ridge member closest to the hip member to ridge connection also have a much higher axial load and bending moment than other rafters located further away from this point. The design of hip members and rafters for these high combined forces makes it uneconomical to construct these members out of cold-formed steel for unsupported hip roof framing systems. To essentially eliminate the axial force in the hip member and the excessive axial compressive force in the rafter, a column to support the upper end of the hip members was introduced at the point where the hip members and ridge meet. All rafters can then be treated as a typical rafter design as detailed in the *Prescriptive Method* (AISI 2002). The hip member is considered a simply supported, single span beam supported at the lower end by the building corner and by the column at the upper end designed primarily for bending and deflection. Tables were developed and are provided for hip members, supporting columns and connections.

### 2.2 Loads

Loads used for the analysis and design of the hip framing are roof dead load (D), roof live load ( $L_r$ ), snow load (S) and wind load (W). ASCE7-05 (ASCE 2005) was used to determine the MWFRS wind load on the hip members, columns and their corresponding connections. LRFD load combinations were used from ASCE7-05 to identify the critical design moments for bending, axial

loads and connections. The hip members were analyzed as simple span beams with a triangular load based on the tributary area. Figure 2.2 shows the tributary area for the hip members.

### **2.2.1 Dead Load (D)**

The roof dead load of 7 psf used for design was taken from Table A1-1 of the *Prescriptive Method* (AISI 2002). The dead load was applied as previously described in Section 1.1.1 and shown in Figure 1.5.

### **2.2.2 Roof Live Load ( $L_r$ )**

According to the *Prescriptive Method*, the minimum roof live load used for roof framing is 16 psf. This load was applied on the horizontal projected area of the hip member.

### **2.2.3 Roof Snow Load (S)**

Ground snow load was considered up to a maximum of 70 psf. The roof design snow load was determined by multiplying the ground snow load by 0.7 which is the current load determination methodology described in the *Prescriptive Method*. The calculated roof snow load was then applied vertically on the horizontally projected area.

### **2.2.4 Wind Load (W)**

For rafter design, component and cladding (C & C) wind loads are used in load combinations. The rafters receive wind loads from cladding which meets the definition of a component. Wind loads applied to the hip members and supporting columns were determined based on Main Wind Force-Resisting System (MWFRS) rather than C & C loads. Hip members are loaded primarily from the jack rafters with a minor portion coming directly from the cladding. Hip members also receive wind from more than surface which is another indication that the member is a part of the MWFRS. The assumption that MWFRS loads are to be used for hip member design is consistent with the design of load bearing wall headers which resist both gravity loads and wind

uplift loads from the rafters or trusses connected directly to them (ASCE 2004, ASCE 2005, AISI 2003). The supporting columns also are designed using MWFRS wind loads because they receive load from the hip members and not the cladding. The columns also receive load from three different roof planes. Method 2 for MWFRS from ASCE7-05 for wind speeds from 85 mph to 150 mph and exposures B and C was used to determine the wind pressures on the different planes of the roof. The wind load is applied perpendicular to the roof planes both for downward and upward forces.

For the development of the tables for member sizes and connections, simplifying assumptions were made to reduce the number of different combinations of building configurations that would be needed for the determination of wind forces. For the maximum downward wind pressures included with dead load and snow load, a 12:12 pitch roof was used. This produces the maximum downward force on the roof. For maximum uplift wind pressures a 24 ft. wide by 48 ft. long building with a 3:12 pitch was used. For both uplift and downward pressures a two-story building was used with 10 ft. tall walls at each level.

### **2.3 Load Combinations**

The following applicable LRFD load combinations from ASCE7-05 were considered for the design of the hip members, the supporting columns and all associated connections.

1.  $1.2D + 1.6(L_r \text{ or } S)$  (downward)
2.  $1.2D + 1.6(L_r \text{ or } S) + 0.8W$  (downward)
3.  $1.2D + 1.6W + 0.5(L_r \text{ or } S)$  (downward)
4.  $0.9D + 1.6W$  (upward)

Where:

D = Dead Load  
L<sub>r</sub> = Roof Live Load  
S = Roof Snow Load  
W = Wind Load

## 2.4 Hip Member Analysis and Design

Hip members are built-up sections consisting of a C-shape and a track section as previously described in Section 1 (Figure 1.3). These built-up sections must be the same depth members as the rafters used so that a wall pocket will not be required in the supporting wall corner. Hip members were limited to a maximum of 12-in deep sections with up to 2-inch wide flanges and a maximum thickness of 97 mils. The yield strength was limited to  $F_y = 50$  ksi because of the thickness of material generally required and the added bending capacity provided by the higher strength material. Only single built-up sections were considered due to the excessive width of multiple members and the difficulty of connecting multiple members at the ridge to adequately transfer loads from the multiple webs to the supporting column.

The hip member is considered to be laterally supported at each rafter connection. Because the hip is in the same plane as the other roof rafters, the connections will laterally brace the top flange under gravity loads and the bottom compression flange when uplift loads are considered. The maximum rafter spacing according to the *Prescriptive Method* is 24-inches on center, therefore the maximum unsupported length used was 34-inches (the diagonal distance between rafter connections). The unsupported length for bending about the major axis will be the actual length of the member. The cantilever at the overhang was conservatively ignored in calculating the maximum moment and deflection.

Deflection criteria used for the design of the hip member is the same as required by the *Prescriptive Method*. The total load deflection limit was  $L/180$  and the snow load deflection limit was  $L/240$ .

The maximum spans for hip members given in Table 2.1 are the maximum horizontal projection of the hip. An example of the strength and deflection calculations for a typical hip member



is provided in Section A.1 of Appendix A. To determine the hip member sizes in the selection table, a 12:12 pitch roof was used for maximum downward wind pressures and a 3:12 pitch roof was used for maximum uplift wind pressures. This was done for simplicity so that only one table need be provided in the *Prescriptive Method*. Figures 2.3, 2.5 and 2.6 show the connection of hip members at the ridge and exterior walls respectively. Tables 2.3, 2.4 and 2.5 provide screw requirements for these connections for both gravity loads and uplift due to wind.

## **2.5 Hip Member Support Column**

As stated previously, a column is used as a support member for the upper end of the hips to essentially eliminate the need to consider axial forces in the hip members. This reduces the size of the hip members that would have been required for unsupported hip framing because they are designed for bending only rather than bending combined with axial compression. For example, the hip member for the unsheathed 3:12 pitch roof (M230 in Figure 1.9) has 6.62 kips of axial compression at the point of maximum moment (Table 1.3). This axial compression is eliminated with the introduction of the support column. The columns and the connections were designed for both gravity loads and uplift loads due to wind.

### **2.5.1 Column Above Ceiling**

The columns above the ceiling are supported at the level of the ceiling and extend up to the intersection of the roof ridge member and the hip members. These columns are made up of two C-section in a box configuration. This configuration was chosen because it has a generally low slenderness ratio and is relatively easy to construct the connections at the ceiling and the ridge. The two C-sections are stitched together with plates as shown in Figure 2.6. The spacing was chosen to satisfy the requirements of Section E4.2 of the *AISC Specification* (AISC 2001). This column supports significant axial loads and therefore requires an interior wall or other supporting element

below the ceiling as described in Section 2.5.2 (Figure 2.6). A continuous load path to the foundation at the lowest level must also be provided for both gravity and uplift loads. The column sizes for various building widths and ground snow loads are given in Table 2.2. For simplicity, all columns were designed based on a 12:12 pitch roof. By making this assumption only one column selection table is required. Since there will be a very limited number of columns required on any particular structure, this is not an overly conservative assumption. The uplift strap and screw requirements for this column are found in Table 2.5. An example of strength calculations for a hip support column is provided in Section A.2 of Appendix A.

### **2.5.2 Column Support Below Ceiling**

A support for the columns above the ceiling must be provided to adequately deliver the roof load from the hips to the foundation. This can be done by either locating a bearing wall or an isolated column directly below the upper column with adequate axial and connection strength to transfer gravity and uplift loads. The bearing wall will require multiple wall studs for support of the attic column for most load conditions in addition to adequate connections to resist tension forces produced by wind uplift. An isolated column may be made up of multiple C-shaped sections, forming a box type section to facilitate attachment of gypsum wall board. An example of strength calculations for a hip support column is provided in Section A.3 of Appendix A.

## **2.6 Connections**

To adequately transfer gravity and wind uplift loads between the hip members and supporting members, connections must be designed to resist the maximum design load as determined by the appropriate load combinations. These connections must also be simple to understand and construct to be appropriate for use in the *Prescriptive Method* (AISI 2002). The

connections detailed in this report are the hip member connections at the ridge and at the wall corner and the upper column connection to the support below at the ceiling.

### **2.6.1 Hip Member Connection at Ridge**

The connection of the two hip members and the ridge member to the supporting column must transfer gravity and uplift loads from the hip members to the column. There is very little load to be transferred from the ridge member to the column since the primary purpose of the ridge is to provide a connection point for rafters and maintain alignment of the rafters until the sheathing is attached. It is also possible to have rafters framing in at this location depending on the layout of the rafters and jack rafters. Figure 2.1 shows the layout when rafters and jack rafters do not align with the hip member connection. An example of the connection design for the clip angle to transfer loads from the hip members to the supporting column is provided in Section A.4 of Appendix A.

The connection as shown in Figures 2.3 and 2.4 was developed through evaluating various alternatives and weighing the advantages and disadvantages of each one. Of primary concern was a direct load path, straightforward and relatively simple to construct. Some of the advantages and disadvantages of this connection are as follows:

- This connection provides a direct connection between both webs of the hip members with only about 1 ¼" eccentricity at the worst case. Load transfer is through screws in shear connecting the bent CFS plates to the hip members and the column.
- Uplift is easily accommodated by the same screws used to transfer the gravity loads to the column.
- The connection of the ridge member to the column is not required to transfer significant vertical load and therefore a nominal attachment with a minimum number of screws suffices.

- This connection does not allow for the rafters to come into the center of the connection easily because of the clips and screws already at those locations.
- The column is restricted to the location of the intersection of the hip members. This is somewhat of a disadvantage because it does not allow for flexibility in locating the column in the living space. If the column were to be allowed to be located away from the intersection of the hip members back along the ridge member, then the ridge member becomes a load carrying member and must be designed for bending, web crippling and shear. Also, the connection of the hip members to the ridge member does not then easily allow for load transfer from both webs of the hip member to the ridge member which is especially important for the higher hip member reactions.

### **2.6.2 Hip Member Connection at Wall Corner**

The connection of the hip member to the wall at the corner must be designed to transfer gravity and uplift loads from the roof. This is the smaller reaction of the hip member and therefore less load is required to be transferred at this end. The connection for this condition is shown in Figure 2.5 and the number of screws required to transfer uplift forces to the wall through a strap are given in Table 2.4. The minimum requirements of Section F7.2 of the Prescriptive Method will apply for the strap however the number of screws for the attachment will be according to Table 2.4. An example showing the calculations for the uplift strap is provided in Section A5 of Appendix A.

### **2.6.3 Hip Support Column Connection at the Ceiling**

The connection of the upper column located in the attic space with supporting elements must be designed to transfer gravity and uplift loads from the roof. Figure 2.6 shows the condition where the upper column aligns with a bearing wall in the living space. A column of multiple studs is shown in the wall and the connection consists of straps tying the two column members together

attached with screws in shear. The number of screws required for the straps are given in Table 2.5. An example showing the calculations for the uplift strap is provided in Section A6 of Appendix A.

## **2.7 Alternate Hip and Ridge Member Configuration**

The traditional hip or ridge member that has been used when framing a cold-formed steel roof assembly has been a C-section nested in a track section (Figure 1.3) and is the configuration used in this report. However, this framing concept requires that the end of each roof rafter be cut on a slope when connecting to the ridge member and on a slope and a skew when framing into the hip member. This is not a desirable framing concept because of the required labor to ensure accurate connections for the rafters to the hip or the ridge. Therefore, for this study, alternate hip and ridge member configurations were studied with the intent of developing an efficient section which will allow the rafters to be cut square and still satisfy the structural requirements for strength and serviceability.

The method of hip roof analysis used in Part 2 of this report requires the hip member to resist significant bending moment and large end reactions both from gravity loads and wind uplift loads. It was determined that the best configuration for this member is the C-section nested in a track for strength, serviceability and ease of connection. Therefore, alternate configurations were not developed for this member.

The ridge member however, is only needed for the common connection point of rafters (Figure 1.2). The ridge member is used to tie the framing system of rafters together and has only minimum requirements for strength and serviceability. Various section configurations were studied, three of which are shown in Figures 2.8, 2.9 and 2.10. All of these sections eliminate the need to cut the rafters at a slope, thus simplifying that part of the connection. However, the ridge member itself becomes much more complicated with the addition of various special cold-formed sections.

The connection of the ridge member at the hip member support column (Figure 2.3) also becomes more complicated. For these reasons it would appear that revising the ridge member to accommodate square cuts on the ends of the rafters is not really that practical since it may actually cost more to construct an alternate ridge member than could possibly be saved in changing from a sloped cut to a square cut on the rafters.

## **2.8 Conclusions**

Hip roof rafters are common means of roof framing for residential construction. However, the *Standard for Cold-Formed Steel Framing - Prescriptive Method for One and Two Family Dwellings* (American 2002) does not provide information for hip roof rafter framing. Thus, the focus of this study was to define the design requirements for the roof rafter and to generate the requisite tables of member sizes and connection details. The report explains the analysis and design assumptions that were used to generate the tables and details.

The traditional hip rafter or ridge member that has been used when framing a cold-formed steel roof assembly has been a C-section nested in a track section. This framing concept requires that the end of each roof rafter be cut on a slope when connecting to the ridge member and on a slope and a skew when framing into a hip member. This is not a desirable framing concept because of the required labor to ensure accurate connections for the rafters to the hip or the ridge. Thus alternative framing concepts were developed for the rafters to the ridge member that would eliminate the need for the sloped connection detail. It was inconclusive whether or not an alternate ridge member configuration would actually be more economical when the added cost of fabricating the ridge member is considered.

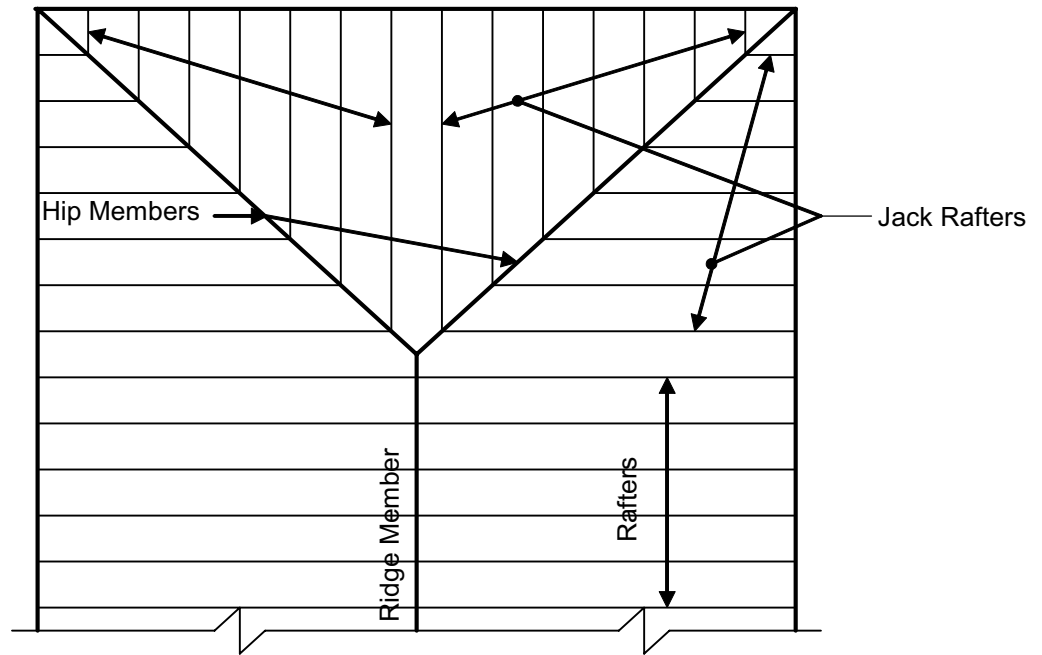

Figure 2.1: Hip roof framing members.

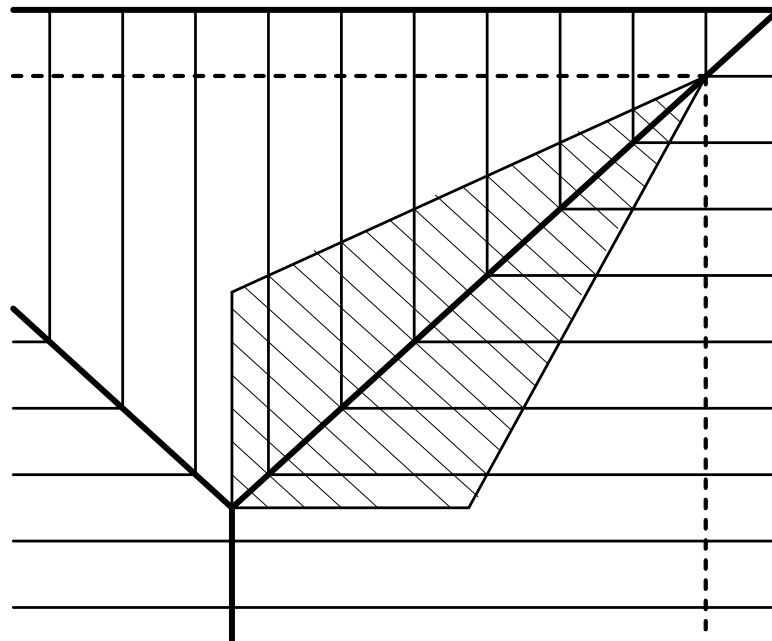
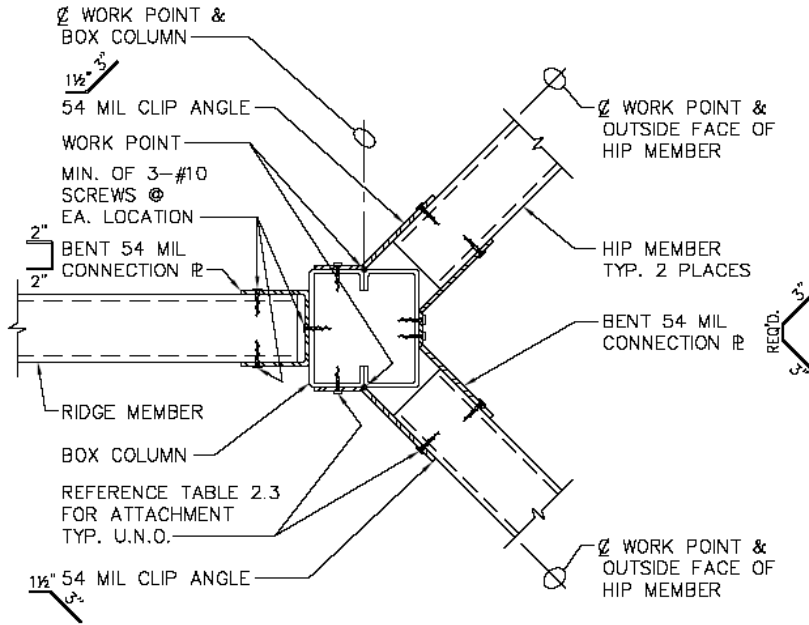
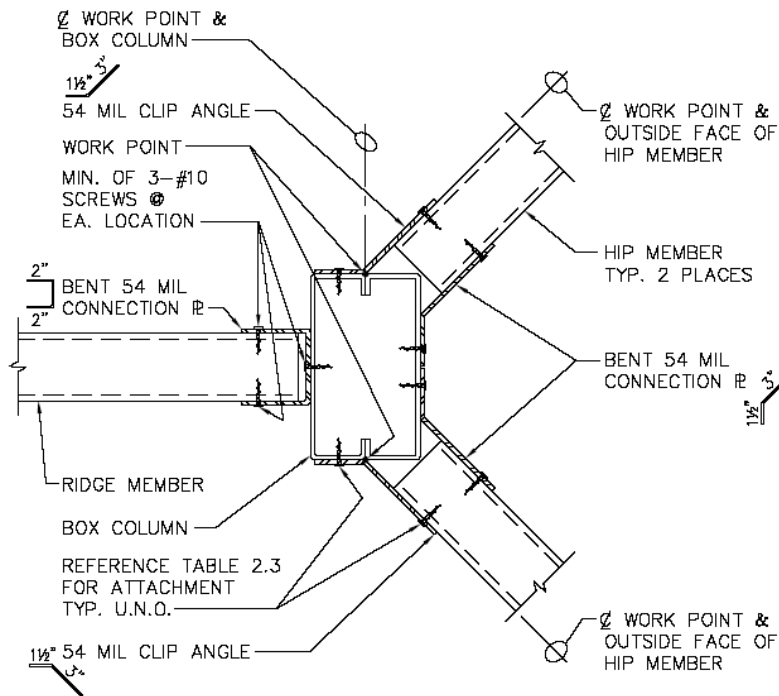

Figure 2.2: Tributary area for hip member indicated by hatching.



NOTE: RAFTERS NOT SHOWN FOR CLARITY

### CONNECTION @ 3 1/2" BOX COLUMN



NOTE: RAFTERS NOT SHOWN FOR CLARITY

### CONNECTION @ 5 1/2" BOX COLUMN

Figure 2.3: Hip members to ridge member connection plan view.



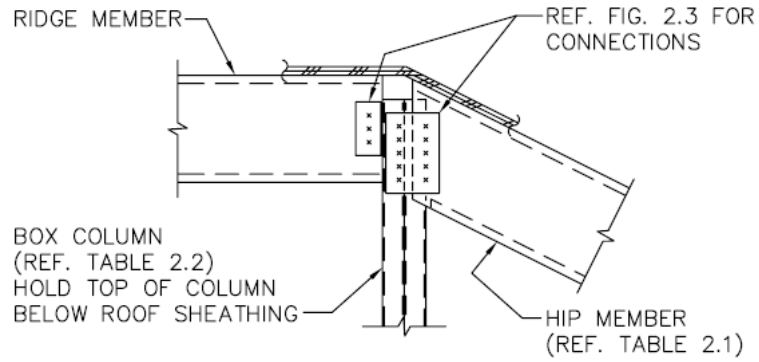

Figure 2.4: Hip member to ridge member connection elevation view.

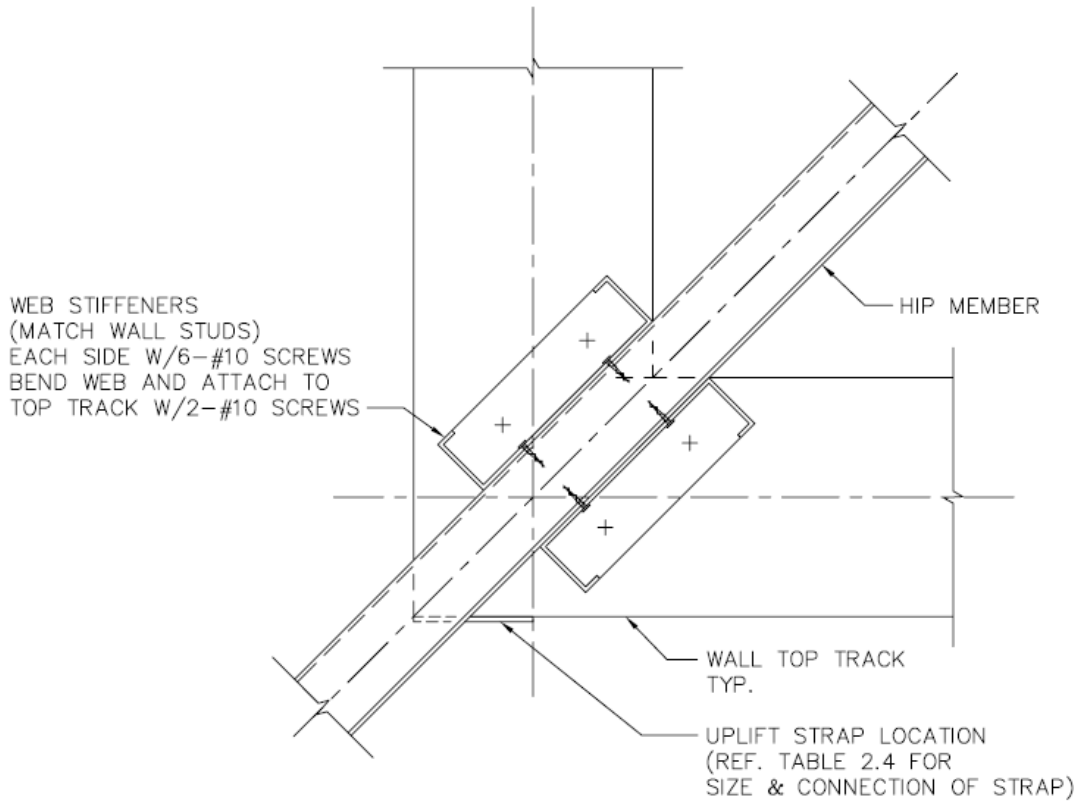

Figure 2.5: Hip member wall connection at ceiling plan view

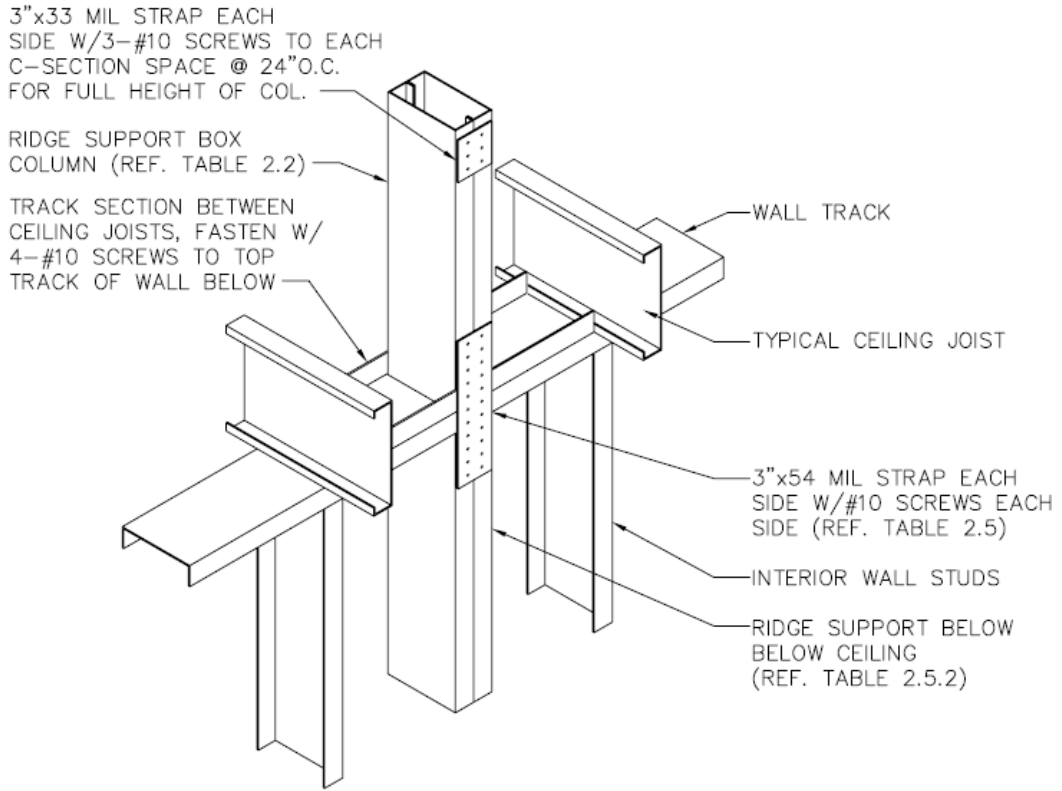

Figure 2.6: Hip member support column connection at ceiling.

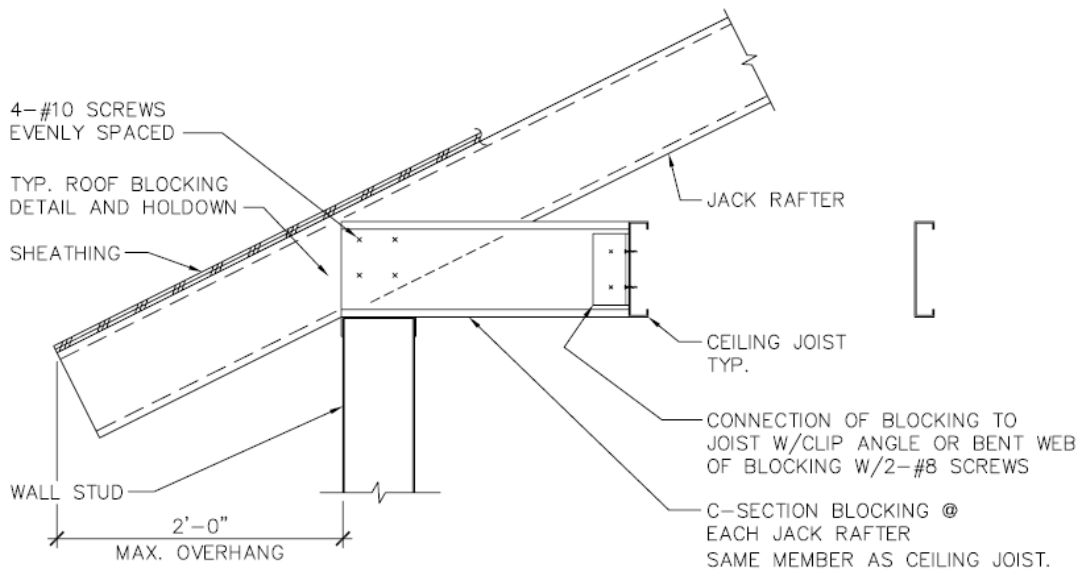

Figure 2.7: Section through end wall.

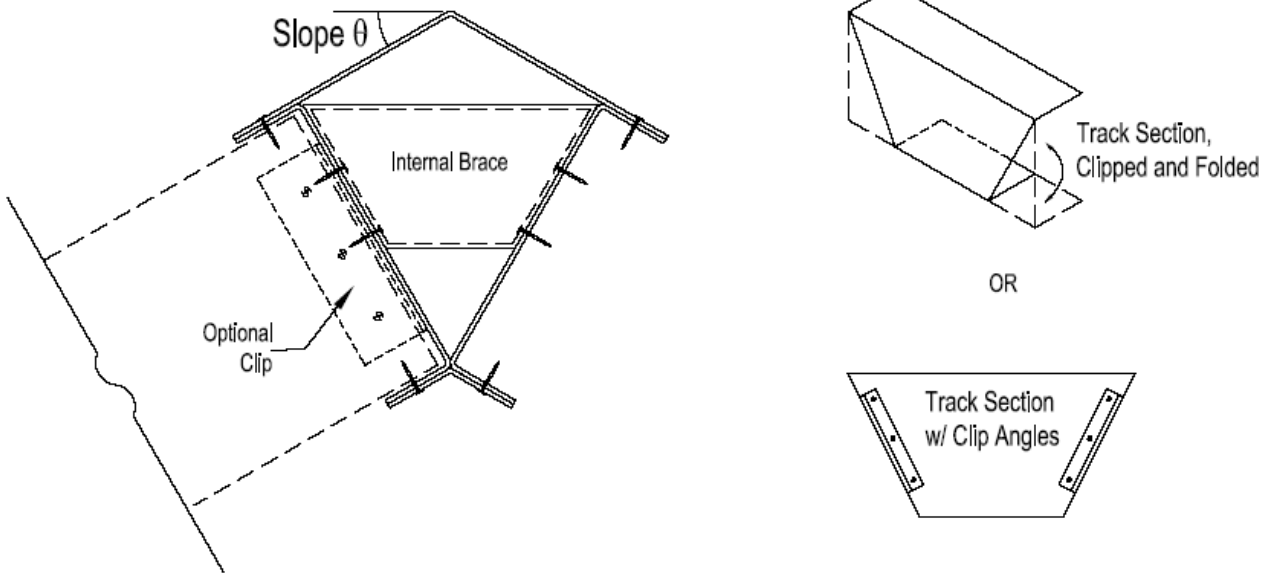

Figure 2.8: Alternate ridge member option 1

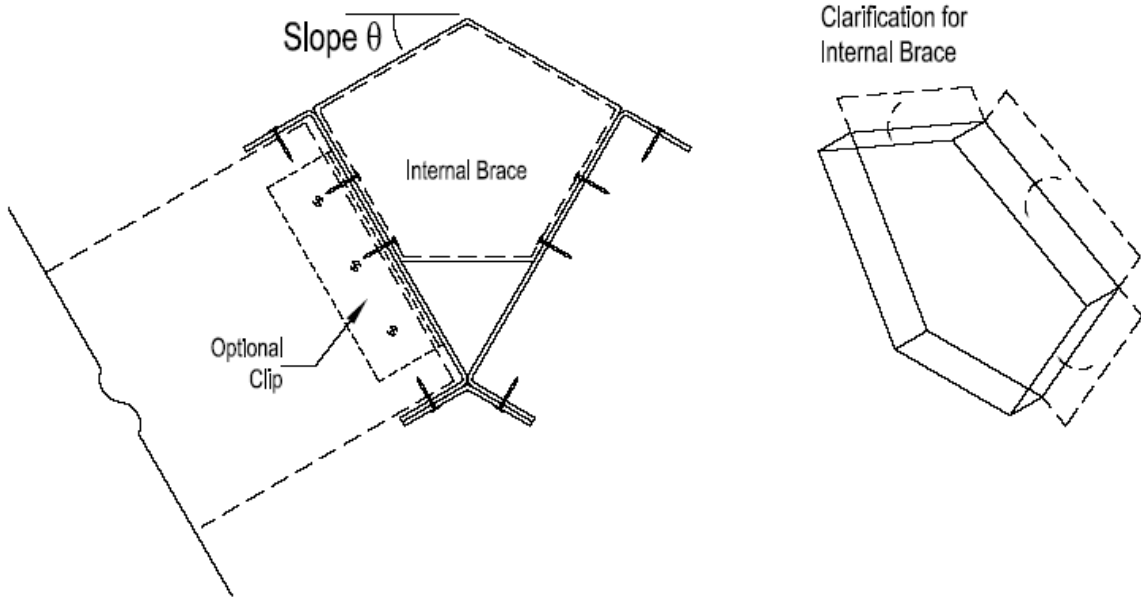

Figure 2.9: Alternate ridge member option 2

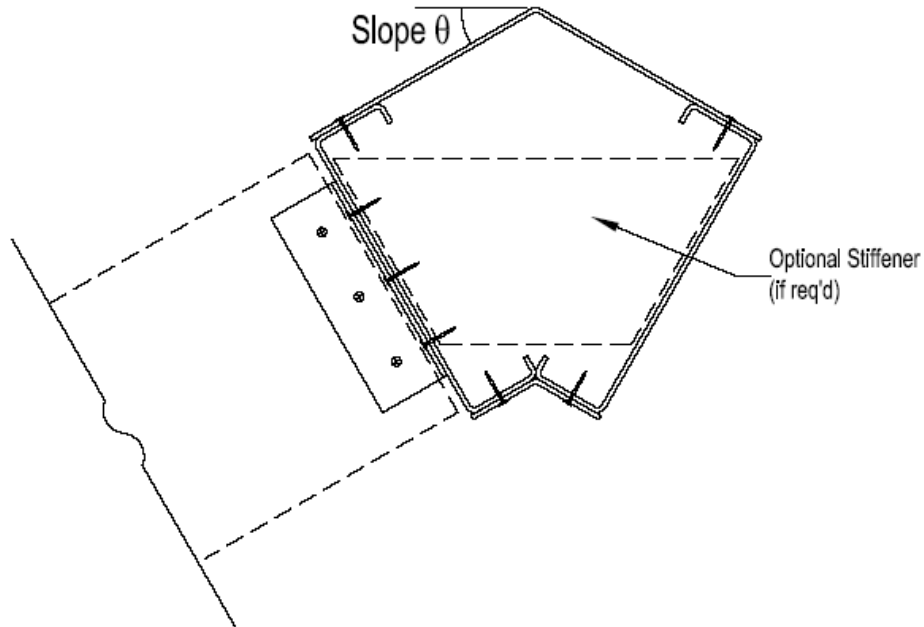

Figure 2.10: Alternate ridge member option 3

Table 2.1: Hip member selection table

Hip Member Selection Table <sup>1</sup>				
Building Width (feet)	Ground Snow Load			
	20 psf	30 psf	50 psf	70 psf
24	800S162-68	800S162-68	800S162-97	1000S162-97
	800T150-68	800T150-68	800T150-97	1000T150-97
28	1000S162-68	1000S200-68	1000S162-97	1200S162-97
	1000T150-68	1000T200-68	1000T150-97	1200T150-97
32	1000S162-97	1000S162-97	1200S200-97	-
	1000T150-97	1000T150-97	1200T200-97	-
36	1200S162-97	-	-	-
	1200T150-97	-	-	-
40	-	-	-	-

For SI: 1 inch = 25.4 mm, 1 foot = 0.305 m, 1 mph = 1.61 km/hr

<sup>1</sup> The depth of the roof rafters are to be the same depth as the hip member selected.

Table 2.2: Hip member support column selection table

Hip Support Column <sup>1</sup> Selection Table				
Building Width (ft)	Ground Snow Load (psf)			
	20	30	50	70
24	2-350S162-33	2-350S162-33	2-350S162-43	2-350S162-54
28	2-350S162-54	2-550S162-54	2-550S162-68	2-550S162-68
32	2-550S162-68	2-550S162-68	2-550S162-97	-
36	2-550S162-97	-	-	-
40	-	-	-	-

For SI: 1 inch = 25.4 mm, 1 foot = 0.305 m, 1 psf = 0.0479 kN/m<sup>2</sup>

<sup>1</sup> Box shape columns only .

<sup>1</sup> F<sub>y</sub> = 33 ksi for 33 and 43 mil material and F<sub>y</sub> = 50 ksi for thicker material.

Table 2.3: Hip member to support column screw attachment requirements

Building Width (ft)	Number of No. 10 screws in each framing angle <sup>1,2</sup>			
	Ground Snow Load (psf)			
	20	30	50	70
24	10	10	10	12
28	10	10	14	18
32	10	12	16	-
36	14	-	-	-
40	-	-	-	-

For SI: 1 inch = 25.4 mm, 1 foot = 0.305 m, 1 psf = 6.895 kPa

<sup>1</sup> Screws are to be divided equally between the connection to the hip member and the column.

<sup>2</sup> The number of screws required in each framing angle shall not be less than shown in Table 2.5.

<sup>3</sup> F<sub>y</sub> = 50 ksi for the framing angle.

Table 2.4: Uplift strap connection requirements for hip member to wall

EXPOSURE A/B	Basic Wind Speed (mph)									
	85	90	100	110	120	130	140	150		
EXPOSURE C			85	90	100	110	120	130	140	150
Building Width (feet)	Number of No. 10 Screws in Each End of a 1-1/2 inch by 54 mil Steel Strap <sup>1,2</sup>									
24	2	2	2	3	3	4	5	6	7	8
28	2	3	3	3	4	5	6	8	9	10
32	3	4	4	4	6	7	8	10	11	13
36	3	5	5	5	7	9	10	12	14	17
40	-	-	-	-	-	-	-	-	-	-

For SI: 1 inch = 25.4 mm, 1 foot = 0.305 m, 1 mph = 1.61 km/hr

<sup>1</sup> A single strap is required located either side of the hip member.

<sup>2</sup> Connections in the shaded area require two straps with half the number of screws shown in each end of each strap.

<sup>3</sup> Space screws at 0.75-inch on center and provide a minimum of 0.75-inch end distance.

<sup>4</sup>  $F_y = 50$  ksi for the strap.

Table 2.5: Uplift strap connection requirements for hip support column at ceiling.

EXPOSURE A/B	Basic Wind Speed (mph)									
	85	90	100	110	120	130	140	150		
EXPOSURE C			85	90	100	110	120	130	140	150
Building Width (feet)	Number of No. 10 Screws in Each End of Each 3 inch by 54 mil Steel Strap <sup>1,2</sup>									
24	3	3	4	4	6	7	8	10	12	14
28	4	4	6	6	8	10	12	14	16	19
32	5	6	8	8	11	13	16	18	22	25
36	7	8	10	11	14	17	20	24	27	-
40	-	-	-	-	-	-	-	-	-	-

For SI: 1 inch = 25.4 mm, 1 foot = 0.305 m, 1 mph = 1.61 km/hr

<sup>1</sup> Two straps are required, one on each side of the column.

<sup>2</sup> Space screws at 0.75-inch on center and provide a minimum of 0.75-inch end distance.

<sup>3</sup>  $F_y = 50$  ksi for the strap.

## REFERENCES

- American Forest & Paper Association (2001a). *Commentary to the Wood Frame Construction Manual for One- and Two-Family Dwellings*. Washington, DC.
- American Forest & Paper Association (2001b). *Wood Frame Construction Manual for One- and Two-Family Dwellings*. Washington, DC.
- American Institute of Steel Construction (AISC) (2001), *Manual of Steel Construction – Load and Resistance Factor Design*, 3<sup>rd</sup> Edition, AISC, Chicago, IL, November.
- American Iron and Steel Institute (AISI) (2001), *AISI, North American Specification for the Design of Cold Formed Steel Structural Members*, 2001 Edition with 2004 Supplement, American Iron and Steel Institute, Washington, DC.
- American Iron and Steel Institute (AISI) (2002), *Standard for Cold-Formed Steel Framing – Prescriptive Method for One and Two Family Dwellings*, AISI, Washington, D.C.
- American Iron and Steel Institute (AISI) (2003), *Commentary on the Standard for Cold-Formed Steel Framing – Prescriptive Method for One and Two Family Dwellings*, AISI, Washington, D.C.
- American Iron and Steel Institute (AISI) (2004a), *AISI Standard for Cold-Formed Steel Framing – Wall Stud Design*, AISI, Washington, D.C.
- American Iron and Steel Institute (AISI) (2004b), *AISI Standard for Cold-Formed Steel Framing – Lateral Design*, AISI, Washington, D.C.
- APA – The Engineered Wood Association (APA) (2004), *Panel Design Specification*, APA, Tacoma, WA, March 2004.
- American Society of Civil Engineers (ASCE) (2004), *Guide to the Use of the Wind Load Provisions of ASCE7-02*, New York, NY.
- American Society of Civil Engineers (ASCE) (2005), *Minimum Design Loads for Buildings and Other Structures*, ASCE 7-05, New York, NY.
- International Code Council (ICC) (2003), *International Building Code*, ICC, Falls Church, VA.
- RISA-3D Software (RISA 2005), *RISA-3D Version 5.15*, RISA Technologies, Foothill Ranch, CA.
- RSG Software (RSG) (2005), *CFS Version 5.0.2*, RSG Software, Inc., Lee's Summit, MO.
- Stalnaker, Judith J., and Harris, Ernest C. (1999), *Structural Design in Wood*, 2<sup>nd</sup> Edition, Kluwer Academic Publishers.
- Yu, Wei-Wen (2000). *Cold-Formed Steel Design*, 3<sup>rd</sup> Edition, New York, NY, John Wiley & Sons, Inc.

## APPENDIX A – DESIGN CALCULATIONS

### A1 Hip Member Design (Section 2.3)

#### A1.1 Design Objective:

Determine if a hip member built-up from a 1000S162-97 and a 1000T150-97 is adequate for the design assumptions listed below. The member is to be checked for all appropriate LRFD load combinations. Bending moment will be calculated based on the horizontal projected span. All references are to the *North American Specification for the Design of Cold-Formed Steel Structural Members* (AISI, 2001), unless otherwise noted.

#### A1.2 Design Assumptions:

Rafter Spacing =	24 in
Roof Pitch =	3:12
Roof Slope = $\tan^{-1}(3:12) =$	14.04°
Building Width =	32 ft
Building Length =	60 ft
Building Eave Height =	21 ft (2-story)
Wall height =	10 ft
Roof Dead Load =	7 psf
Wind Speed =	110 mph
Wind Exposure Category =	C
Ground Snow Load =	30 psf

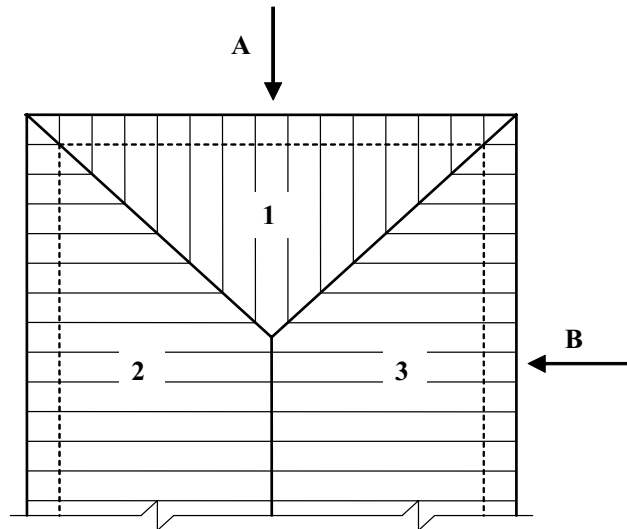

Figure A1: Roof surfaces and wind directions

#### A1.3 Design Loads:

##### Dead Load:

Uniform Roof Dead Load = 7 psf  
 Total roof dead load on the horizontal projected area of each hip:

$$D = \frac{(16 \text{ ft})^2}{2} \cdot \frac{7 \text{ psf}}{\cos \theta} = 924 \text{ lbs}$$

##### Roof Live Load:

Minimum roof live load = 16 psf  
 Total roof live load on the horizontal projected area:

$$L_r = \frac{(16 \text{ ft})^2}{2} (16 \text{ psf}) = 2048 \text{ lbs}$$

##### Roof Snow Load:

Roof snow load =  $0.7(30 \text{ psf}) = 21 \text{ psf}$  (Governs)  
 Total snow load on the horizontal projected area:

$$S = \frac{(16 \text{ ft})^2}{2} (21 \text{ psf}) = 2688 \text{ lbs}$$



Wind Loads:

Wind loads are calculated in accordance with ASCE 7-2005 Method 2 – Analytical Procedure for MWFRS (ASCE, 2005).

<u>Equation:</u>	<u>Comments:</u>	<u>ASCE7 Reference:</u>
$p = qGC_p - q_iGC_{pi}$	Rigid Building of All Hts.	6.5.12.2, Eq. 6-17
$q = q_i = q_h = 0.00256K_zK_{zt}K_dV^2I$		6.5.10, Eq 6-15

Where:

$K_z = 0.924$	Exp. C, Case 1, $z = 23$ ft	Table 6-3
$K_{zt} = 1.0$	No Topographic Factor	
$K_d = 0.85$		Table 6-4
$V = 110$ mph	3-Second Gust Wind Speed	
$I = 1.0$	Residential Building (Cat I)	Table 1-1, Table 6-1

$$q_h = 0.00256(0.924)(1.0)(0.85)(110)^2(1.0) = 24.3 \text{ lb/ft}^2$$

$G = 0.85$	Rigid Structure	Section 6.5.8.1
$GC_{pi} = -0.18$ or $+0.18$	Enclosed Buildings	Figure 6-5

Wind pressures for wind direction A ( $h/L = 23/60 = 0.38$ ):

Surface 1: $C_p = -0.6, -0.09$	Figure 6-6
Surface 2: $C_p = -0.9, -0.18$	Figure 6-6
Surface 3: $C_p = -0.9, -0.18$	Figure 6-6

$p_1 = 24.3(0.85)(-0.6) - 24.3(\pm 0.18) = \underline{-16.8 \text{ psf}}, -8.0 \text{ psf}$	Uplift
or	
$p_1 = 24.3(0.85)(-0.09) - 24.3(\pm 0.18) = \underline{-6.2 \text{ psf}}, +2.5 \text{ psf}$	Downward

$p_2 = p_3 = 24.3(0.85)(-0.9) - 24.3(\pm 0.18) = \underline{-23.0 \text{ psf}}, -14.2 \text{ psf}$	Uplift
or	
$p_2 = p_3 = 24.3(0.85)(-0.18) - 24.3(\pm 0.18) = \underline{-8.1 \text{ psf}}, +0.7 \text{ psf}$	Downward

Wind pressures for wind direction B ( $h/L = 23/32 = 0.72$ ):

Surface 1: $C_p = -1.08, -0.18$	Figure 6-6
Surface 2: $C_p = -0.54$	Figure 6-6
Surface 3: $C_p = -0.83, -0.18$	Figure 6-6

$p_1 = 24.3(0.85)(-1.08) - 24.3(\pm 0.18) = \underline{-26.7 \text{ psf}}, -17.9 \text{ psf}$	Uplift
or	
$p_1 = 24.3(0.85)(-0.18) - 24.3(\pm 0.18) = \underline{-8.1 \text{ psf}}, +0.7 \text{ psf}$	Downward

$$p_2 = 24.3(0.85)(-0.54) - 24.3(\pm 0.18) = \underline{-15.5 \text{ psf}}, -6.8 \text{ psf} \quad \text{Uplift}$$

$$p_3 = 24.3(0.85)(-0.83) - 24.3(\pm 0.18) = \underline{-21.5 \text{ psf}}, -12.8 \text{ psf} \quad \text{Uplift}$$

or

$$p_3 = 24.3(0.85)(-0.18) - 24.3(\pm 0.18) = -8.1 \text{ psf}, \underline{+0.7 \text{ psf}} \quad \text{Downward}$$

Wind direction A governs for downward pressure with  $P_1 = +2.5 \text{ psf}$  and  $P_2 = P_3 = +0.7 \text{ psf}$

Vertical component of downward wind load:

$$P_1 = 2.5 \text{ psf} \times \cos \theta = 2.4 \text{ psf}$$

$$P_2 = P_3 = 0.7 \text{ psf} \times \cos \theta = 0.7 \text{ psf}$$

Total downward wind load on the horizontal projected area:

$$W_{\text{down}} = \frac{(16 \text{ ft})^2}{4 \times \cos \theta} [2.4 \text{ psf} + (0.7 \text{ psf})] = 205 \text{ lbs}$$

Wind direction B governs for uplift with  $P_1 = -26.7 \text{ psf}$  and  $P_3 = -21.5 \text{ psf}$

Vertical component of uplift wind load:

$$P_1 = -26.7 \text{ psf} \times \cos \theta = -25.9 \text{ psf}$$

$$P_3 = -21.5 \text{ psf} \times \cos \theta = -20.9 \text{ psf}$$

Total uplift wind load on the horizontal projected area:

$$W_{\text{uplift}} = \frac{16^2}{4 \times \cos \theta} [-25.9 \text{ psf} + (-20.9 \text{ psf})] = -3087 \text{ lbs}$$

#### A1.4 Load Combinations:

1.  $1.2D + 1.6(L_r \text{ or } S) + 0.8W_{\text{down}}$
2.  $1.2D + 1.6W_{\text{down}} + 0.5(L_r \text{ or } S)$
3.  $0.9D + 1.6W_{\text{uplift}}$

Uplift check

#### Design Load:

Max. Downward (load case 1),  $W_u = 1.2(924 \text{ lbs}) + 1.6(2688 \text{ lbs}) + 0.8(205 \text{ lbs}) = 5573 \text{ lbs}$

Max. Uplift (load case 3),  $W_u = 0.9(924 \text{ lbs}) + 1.6(-3087 \text{ lbs}) = -4107 \text{ lbs}$

#### A1.5 Material and Section Properties:

$F_y$  (track and C-section) = 50 ksi

$S_x = 6.4479 \text{ in}^3$  (from CFS v. 5.0.2)

$I_x = 33.387 \text{ in}^4$  (from CFS v. 5.0.2)

$\phi M_n = 271.39 \text{ k-in}$  (from CFS v. 5.0.2)

$\phi V_n = 9.542 \text{ k}$  (from CFS v. 5.0.2)

#### A1.6 Bending Check

Maximum downward load governs for bending. Unsupported length of the compression flange for both positive and negative moment is the same. The jack rafters connected to the hip member resists lateral torsional buckling for both gravity loads and uplift.

Total triangular load supported by the hip member:  $W_u = 5573 \text{ lbs}$

Applied bending moment:

$$M_u = 0.128W_u L = 0.128(5573 \text{ lbs})(16 \text{ ft})\sqrt{2} \left( \frac{12}{1000} \right) = 194 \text{ k-in}$$

$$M_u = 194 \text{ k-in} \leq \phi M_n = 271 \text{ k-in} \quad \text{OK}$$

**Therefore, the hip member composed of 1000S167-97 and 1000T1500-97 is adequate for bending.**

### A1.7 Shear Check

Maximum downward load governs for bending. Unsupported length of the compression flange for both positive and negative moment is the same. The jack rafters connected to the hip member resists lateral torsional buckling for both gravity loads and uplift.

Total triangular load supported by the hip member:  $W_u = 5573 \text{ lbs}$

Applied shear:

$$V_u = \frac{2}{3}W_u = \frac{2}{3}(5573 \text{ lbs}) = 3715 \text{ lbs}$$

$$V_u = \frac{3715 \text{ lbs}}{1000} = 3.715 \text{ k} \leq \phi V_n = 9.54 \text{ k} \quad \text{OK}$$

**Therefore, the hip member composed of 1000S167-97 and 1000T1500-97 is adequate for shear.**

### A1.8 Deflection Check

Total load deflection limit is  $L/180$  and is based on service dead load plus roof snow.

Total service load supported by the hip member:  $W = 924 \text{ lbs} + 2688 \text{ lbs} = 3612 \text{ lbs}$

$$\Delta_{allow} = \frac{L}{180} = \frac{22.63 \text{ ft} \times 12}{180} = 1.51 \text{ in}$$

$$\Delta_{tot} = \frac{0.01304WL^3}{EI_x} = \frac{0.01304(3612 \text{ lbs})(22.63 \text{ ft})^3(1728)}{29,500,000 \text{ psi}(33.387 \text{ in}^4)} = 0.96 \text{ in}$$

$$\Delta_{tot} = 0.96 \text{ inches} < \Delta_{allow} = 1.51 \text{ inches} \quad \text{OK}$$

**Therefore, hip member composed of 1000S162-97 and 1000T150-97 is adequate for deflection.**

## A2 Hip Member Support Column above Ceiling (Section 2.5.1)

### A2.1 Design Objective:

Determine if a hip member support column built-up from 2-550S162-68 is adequate for the design assumptions from example A1. The member is to be checked for all appropriate LRFD load combinations. All references are to the *North American Specification for the Design of Cold-Formed Steel Structural Members* (AISI, 2001), unless otherwise noted.

### A2.2 Design Assumptions:

All design assumptions will be the same as used in example A1.

### A2.3 Design Loads:

#### Dead Load:

Uniform Roof Dead Load = 7 psf

Total roof dead load on the horizontal projected area:

$$D = \frac{16^2}{\cos \theta} \cdot \frac{2}{3} (7 \text{ psf}) = 1231 \text{ lbs}$$

#### Roof Live Load:

Minimum roof live load = 16 psf

Total roof live load on the horizontal projected area:

$$L_r = 16^2 \cdot \frac{2}{3} (16 \text{ psf}) = 2730 \text{ lbs}$$

#### Roof Snow Load:

Roof snow load =  $0.7(30 \text{ psf}) = 21 \text{ psf}$  (Governs)

Total snow load on the horizontal projected area:

$$S = 16^2 \cdot \frac{2}{3} (21 \text{ psf}) = 3584 \text{ lbs}$$

#### Wind Loads:

Wind loads are calculated in accordance with ASCE 7-2005 Method 2 – Analytical Procedure for MWFRS (ASCE, 2005).

Wind pressures for wind direction A ( $h/L = 23/60 = 0.38$ ):

Surface 1:  $C_p = -0.6, -0.09$

Figure 6-6

Surface 2:  $C_p = -0.9, -0.18$

Figure 6-6

Surface 3:  $C_p = -0.9, -0.18$

Figure 6-6

$$p_1 = 24.3(0.85)(-0.6) - 24.3(\pm 0.18) = \underline{-16.8 \text{ psf}}, -8.0 \text{ psf}$$

Uplift

or

$$p_1 = 24.3(0.85)(-0.09) - 24.3(\pm 0.18) = -6.2 \text{ psf}, \underline{+2.5 \text{ psf}}$$

Downward

$$p_2 = p_3 = 24.3(0.85)(-0.9) - 24.3(\pm 0.18) = \underline{-23.0 \text{ psf}}, -14.2 \text{ psf} \quad \text{Uplift}$$

or

$$p_2 = p_3 = 24.3(0.85)(-0.18) - 24.3(\pm 0.18) = -8.1 \text{ psf}, \underline{+0.7 \text{ psf}} \quad \text{Downward}$$

Wind pressures for wind direction B ( $h/L = 23/32 = 0.72$ ):

$$\text{Surface 1: } C_p = -1.08, -0.18$$

$$\text{Surface 2: } C_p = -0.54$$

$$\text{Surface 3: } C_p = -0.83, -0.18$$

Figure 6-6

Figure 6-6

Figure 6-6

$$p_1 = 24.3(0.85)(-1.08) - 24.3(\pm 0.18) = \underline{-26.7 \text{ psf}}, -17.9 \text{ psf} \quad \text{Uplift}$$

or

$$p_1 = 24.3(0.85)(-0.18) - 24.3(\pm 0.18) = -8.1 \text{ psf}, \underline{+0.7 \text{ psf}} \quad \text{Downward}$$

$$p_2 = 24.3(0.85)(-0.54) - 24.3(\pm 0.18) = \underline{-15.5 \text{ psf}}, -6.8 \text{ psf} \quad \text{Uplift}$$

$$p_3 = 24.3(0.85)(-0.83) - 24.3(\pm 0.18) = \underline{-21.5 \text{ psf}}, -12.8 \text{ psf} \quad \text{Uplift}$$

or

$$p_3 = 24.3(0.85)(-0.18) - 24.3(\pm 0.18) = -8.1 \text{ psf}, \underline{+0.7 \text{ psf}} \quad \text{Downward}$$

Wind direction A governs for downward pressure with  $P_1 = +2.5 \text{ psf}$  and  $P_2 = P_3 = +0.7 \text{ psf}$

Vertical component of downward wind load:

$$P_1 = 2.5 \text{ psf} \times \cos \theta = 2.4 \text{ psf}$$

$$P_2 = P_3 = 0.7 \text{ psf} \times \cos \theta = 0.7 \text{ psf}$$

Total downward wind load on the horizontal projected area:

$$W_{\text{down}} = \frac{(16 \text{ ft})^2}{4 \times \cos \theta} \cdot 2 \cdot \frac{2}{3} [2.4 \text{ psf} + (0.7 \text{ psf})] = 273 \text{ lbs}$$

Wind direction B governs for uplift with  $P_1 = -26.7 \text{ psf}$ ,  $P_2 = -15.5$  and  $P_3 = -21.5 \text{ psf}$

Vertical component of uplift wind load:

$$P_1 = -26.7 \text{ psf} \times \cos \theta = -25.9 \text{ psf}$$

$$P_2 = -15.5 \text{ psf} \times \cos \theta = -15.0 \text{ psf}$$

$$P_3 = -21.5 \text{ psf} \times \cos \theta = -20.9 \text{ psf}$$

Total uplift wind load on the horizontal projected area:

$$W_{\text{uplift}} = \frac{(16 \text{ ft})^2}{4 \times \cos \theta} \cdot 2 \cdot \frac{2}{3} \left[ -25.9 \text{ psf} + \frac{(-15.0 \text{ psf} - 20.9 \text{ psf})}{2} \right] = -3857 \text{ lbs}$$

#### A2.4 Load Combinations:

1.  $1.2D + 1.6(L_r \text{ or } S) + 0.8W_{\text{down}}$
2.  $1.2D + 1.6W_{\text{down}} + 0.5(L_r \text{ or } S)$
3.  $0.9D + 1.6W_{\text{uplift}}$

Uplift check

#### Design Load:

Max. Downward (load case 1),  $W_u = 1.2(1231 \text{ lbs}) + 1.6(3584 \text{ lbs}) + 0.8(273 \text{ lbs}) = 7430 \text{ lbs}$   
Max. Uplift (load case 3),  $W_u = 0.9(1231 \text{ lbs}) + 1.6(-3857 \text{ lbs}) = -5063 \text{ lbs}$

### **A2.5 Material Properties:**

$$F_y = 50 \text{ ksi}$$

(Section properties generated from CFS v.5.0.2)

$$A = 1.3148 \text{ in}^2$$

$$A_{\text{net}} = 0.95826 \text{ in}^2$$

$$r_x = 2.0865 \text{ in}$$

$$r_y = 1.3148 \text{ in}$$

Unsupported column height:  $h = 16 \text{ ft} \times 3/12 = 4 \text{ ft}$

### **A2.6 Axial Compression:**

$\phi P_n = 32.594 \text{ k}$  (from CFS v. 5.0.2) for axial compression.

$$\phi P_n = 32.594 \text{ k} > P_u = 7.430 \text{ k} \quad \text{OK}$$

### **A2.7 Axial Tension:**

$\phi P_n = 46.715 \text{ k}$  (from CFS v. 5.0.2) for axial tension.

$$\phi P_n = 46.715 \text{ k} > P_u = 5.063 \text{ k} \quad \text{OK}$$

**Therefore, hip member support column composed of 2-550S162-68 is adequate for axial compression and tension.**

### A3 Hip Member Support Column below Ceiling (Section 2.5.2)

#### A3.1 Design Objective:

Determine the number of wall studs required to support the upper column from example A2 for the design assumptions from example A1. The member is to be checked for all appropriate LRFD load combinations. All references are to the *North American Specification for the Design of Cold-Formed Steel Structural Members* (AISI, 2001), unless otherwise noted.

#### A3.2 Design Assumptions:

All design assumptions will be the same as used in example A1.

#### A3.3 Design Loads:

All design area loads will be the same as used in example A2.

#### A3.4 Load Combinations:

1.  $1.2D + 1.6(L_r \text{ or } S) + 0.8W_{\text{down}}$
2.  $1.2D + 1.6W_{\text{down}} + 0.5(L_r \text{ or } S)$
3.  $0.9D + 1.6W_{\text{uplift}}$

Uplift check

#### Design Load:

Max. Downward (load case 1),  $W_u = 1.2(1231 \text{ lbs}) + 1.6(3584 \text{ lbs}) + 0.8(273 \text{ lbs}) = 7430 \text{ lbs}$

Max. Uplift (load case 3),  $W_u = 0.9(1231 \text{ lbs}) + 1.6(-3857 \text{ lbs}) = -5063 \text{ lbs}$

#### A3.5 Material Properties and Design Parameters:

$F_y = 33 \text{ ksi}$

Stud size: 550S162-43 to match width of column above.

Unsupported column height:  $h = 10 \text{ ft}$

Bracing as 1/3 points per *Prescriptive Method* requirements (Section E4.2)

#### Axial Compression:

$\phi P_n = 5.472 \text{ kip/stud}$  (from AISIWIN v7.0) for axial compression.

Use 2-550S162-43 studs:  $\phi P_n = 10.944 \text{ k} > P_u = 7.430 \text{ k}$  **OK**

#### Axial Tension:

$\phi P_n = 10.516 \text{ k/stud}$  (from CFS v. 5.0.2) for axial tension.

Use 2-550S162-43 studs:  $\phi P_n = 21.032 \text{ k} > P_u = 5.063 \text{ k}$  **OK**

**Therefore, hip member support column composed of 2-550S162-43 is adequate for axial compression and tension.**

## A4 Hip Member Connection at Ridge (Section 2.6.1)

### A4.1 Design Objective:

Determine the number of screws required to connect the hips to the supporting column using the design assumptions from example A1. The connection is to be checked for all appropriate LRFD load combinations. All references are to the *North American Specification for the Design of Cold-Formed Steel Structural Members* (AISI, 2001), unless otherwise noted.

### A4.2 Design Assumptions:

All design assumptions will be the same as used in example A1.

### A4.3 Design Loads:

All design area loads will be the same as used in examples A1.

### Determine required number of screws for the connection between the clip angle and the hip member:

No. 10 Screw Shear Capacity (Section E4.3):

#### Connection Shear Limited by Tilting and Bearing (Section E4.3.1):

$t_1 = 0.0566 \text{ in}$	54 mil (Base Metal Thickness)
$t_2 = 0.1017 \text{ in}$	97 mil (Base Metal Thickness)
$d = 0.190 \text{ in}$	No. 10 Screw per Table C-E4-1
$F_{u1} = 65 \text{ ksi}$	50 ksi Steel
$F_{u2} = 65 \text{ ksi}$	50 ksi Steel
$\frac{t_2}{t_1} = 1.7968$	

$P_{ns}$  for  $t_2/t_1 = 1.0$ :

$$P_{ns} = 4.2\sqrt{t_2^3 d F_{u2}} = 4.2\sqrt{(0.1017)^3 (0.190)(65)} = 3.859 \text{ kips} \quad \text{Eq. E4.3.1-1}$$

$$P_{ns} = 2.7t_1 d F_{u1} = 2.7(0.0566)(0.190)(65) = 1.887 \text{ kips} \quad \text{Eq. E4.3.1-2}$$

$$P_{ns} = 2.7t_2 d F_{u2} = 2.7(0.1017)(0.190)(65) = 3.391 \text{ kips} \quad \text{Eq. E4.3.1-3}$$

$$P_{ns} = 1.887 \text{ kips}$$

$P_{ns}$  for  $t_2/t_1 = 2.5$ :

$$P_{ns} = 2.7t_1 d F_{u1} = 2.7(0.0566)(0.190)(65) = 1.887 \text{ kips} \quad \text{Eq. E4.3.1-4}$$

$$P_{ns} = 2.7t_2 d F_{u2} = 2.7(0.1017)(0.190)(65) = 3.391 \text{ kips} \quad \text{Eq. E4.3.1-5}$$

$$P_{ns} = 1.307 \text{ kips}$$



Therefore, nominal shear strength,  $P_{ns} = 1.887$  kips

Connection Shear Limited by End Distance (Section E4.3.2):

Assume end distance  $\geq 1.5d = 1.5(0.190 \text{ in}) = 0.285 \text{ in}$

$$P_n = t_1 e F_{u1} = (0.0566)(0.285)(65) = 1.049 \text{ kips} \quad \text{Eq. E4.3.2-1}$$

$P_n < P_{ns}$ , Therefore determine the minimum end distance so that the shear capacity will not be limited by end distance.

$$e_{\min} = 1.5d \frac{P_{ns}}{P_n} = 1.5(0.190) \frac{1.887}{0.726} = 0.747 \text{ in}$$

**Use 3/4" minimum end distance for screws.**

Shear in Screws (Section E4.3.3):

Assume shear capacity of screw is exceeds tilting/bearing capacity of 33 mil material

Therefore,  $P_{ns} = 1.887$  kips

**Determine Required Number of Screws:**

$$\begin{aligned} \phi P_{ns} &\geq P_u && \text{Section E4} \\ \phi &= 0.50 \end{aligned}$$

$$\text{Number of screws, } n = \frac{P_u}{\phi P_n} = \frac{5.573 \text{ kips} \cdot \frac{2}{3} \cdot \frac{1}{2}}{0.5(1.887 \text{ kips})} = 2.0$$

**Therefore, use 2-#10 screws each leg of clip angle to hip member web.**

**Determine required number of screws for the connection between the clip angle and the column:**

No. 10 Screw Shear Capacity (Section E4.3):

Connection Shear Limited by Tilting and Bearing (Section E4.3.1):

$t_1 = 0.0566 \text{ in}$	54 mil (Base Metal Thickness) for clip angle
$t_2 = 0.0566 \text{ in}$	54 mil (Base Metal Thickness) for column
$d = 0.190 \text{ in}$	No. 10 Screw per Table C-E4-1
$F_{u1} = 65 \text{ ksi}$	50 ksi Steel
$F_{u2} = 65 \text{ ksi}$	50 ksi Steel

$$\frac{t_2}{t_1} = 1.0$$

$$P_{ns} = 4.2\sqrt{t_2^3 d} F_{u2} = 4.2\sqrt{(0.0566)^3 (0.190)} (65) = 1.602 \text{ kips} \quad \text{Eq. E4.3.1-1}$$

$$P_n = 2.7t_1 d F_{u1} = 2.7(0.0566)(0.190)(65) = 1.887 \text{ kips} \quad \text{Eq. E4.3.1-2}$$

$$P_{ns} = 2.7t_2 d F_{u2} = 2.7(0.0566)(0.190)(65) = 1.887 \text{ kips} \quad \text{Eq. E4.3.1-3}$$

$$P_{ns} = 1.887 \text{ kips}$$

Connection Shear Limited by End Distance (Section E4.3.2):

$$P_n = t_1 e F_{u1} = (0.0566)(0.285)(65) = 1.049 \text{ kips} \quad \text{Eq. E4.3.2-1}$$

$P_n < P_{ns}$ , Therefore determine the minimum end distance so that the shear capacity will not be limited by end distance.

$$e_{\min} = 1.5d \frac{P_{ns}}{P_n} = 1.5(0.190) \frac{1.887}{0.726} = 0.747 \text{ in}$$

**Use 3/4" minimum end distance for screws.**

Shear in Screws (Section E4.3.3):

Assume shear capacity of screw is exceeds tilting/bearing capacity of 33 mil material

Therefore,  $P_{ns} = 1.887 \text{ kips}$

**Determine Required Number of Screws:**

$$\phi P_{ns} \geq P_u$$

$$\phi = 0.50$$

Section E4

$$\text{Number of screws, } n = \frac{P_u}{\phi P_n} = \frac{5.573 \text{ kips} \cdot \frac{2}{3} \cdot \frac{1}{2}}{0.5(1.887 \text{ kips})} = 2.0$$

**Therefore, use 2-#10 screws each leg of clip angle to the column.**

## A5 Hip Member Connection at Wall Corner (Section 2.6.2)

### A5.1 Design Objective:

Determine the number of screws required to connect the hips to the supporting wall with a holdown strap for uplift loads using the design assumptions from example A1. The connection is to be checked for all appropriate LRFD load combinations. All references are to the *North American Specification for the Design of Cold-Formed Steel Structural Members* (AISI, 2001), unless otherwise noted.

### A5.2 Design Assumptions:

All design assumptions will be the same as used in example A1. Assume that the wall studs are 33 mil thickness and  $F_y = 33$  ksi material since this is the minimum requirements for these members based on the *Prescriptive Method*.

### A5.3 Design Loads:

All design area loads will be the same as used in example A1.

### Determine the required number of screws for the connection between the hip member and the holdown strap:

No. 10 Screw Shear Capacity (Section E4.3):

#### Connection Shear Limited by Tilting and Bearing (Section E4.3.1):

$t_1 = 0.0566$ in	54 mil (Base Metal Thickness)
$t_2 = 0.0346$ in	33 mil (Base Metal Thickness)
$d = 0.190$ in	No. 10 Screw per Table C-E4-1
$F_{u1} = 65$ ksi	50 ksi Steel
$F_{u2} = 45$ ksi	33 ksi Steel
$\frac{t_2}{t_1} = 0.756$	

$P_{ns}$  for  $t_2/t_1 = 1.0$ :

$$P_{ns} = 4.2\sqrt{t_2^3 d F_{u2}} = 4.2\sqrt{(0.0346)^3 (0.190)(45)} = 0.530 \text{ kips} \quad \text{Eq. E4.3.1-1}$$

$$P_{ns} = 2.7t_1 d F_{u1} = 2.7(0.0566)(0.190)(65) = 1.887 \text{ kips} \quad \text{Eq. E4.3.1-2}$$

$$P_{ns} = 2.7t_2 d F_{u2} = 2.7(0.0346)(0.190)(45) = 0.799 \text{ kips} \quad \text{Eq. E4.3.1-3}$$

Therefore, nominal shear strength,  $P_{ns} = 0.530$  kips

#### Connection Shear Limited by End Distance (Section E4.3.2):

Assume end distance  $\geq 1.5d = 1.5(0.190 \text{ in}) = 0.285 \text{ in}$

$$P_n = t_1 e F_u = (0.0566)(0.285)(65) = 1.049 \text{ kips} \quad \text{Eq. E4.3.2-1}$$

$P_n > P_{ns}$ , Therefore the shear capacity will not be limited by end distance.

Shear in Screws (Section E4.3.3):

Assume shear capacity of screw exceeds tilting/bearing capacity of 33 mil material

Therefore,  $P_{ns} = 518$  kips

**Determine Required Number of Screws:**

$$\phi P_{ns} \geq P_u$$

$$\phi = 0.50$$

Section E4

$$\text{Number of screws, } n = \frac{P_u}{\phi P_n} = \frac{3.087 \text{ kips} \cdot \frac{1}{3}}{0.5(0.530 \text{ kips})} = 3.9$$

**Therefore, use 4-#10 screws each end of holdown strap to hip member and wall stud.**

## A6 Hip Support Column Connection at Ceiling (Section 2.6.3)

### A6.1 Design Objective:

Determine the number of screws required to connect the upper hip member support column to a column below the ceiling with holdown straps for uplift loads using the design assumptions from example A1. The connection is to be checked for all appropriate LRFD load combinations. All references are to the *North American Specification for the Design of Cold-Formed Steel Structural Members* (AISI, 2001), unless otherwise noted.

### A6.2 Design Assumptions:

All design assumptions will be the same as used in example A1. Assume that the wall studs are 33 mil thickness and  $F_y = 33$  ksi material since this is the minimum requirements for these members based on the *Prescriptive Method*.

### A6.3 Design Loads:

All design area loads will be the same as used in example A1.

### Determine the required number of screws for the connection between the supporting column below the ceiling and the holdown strap (Figure 2.5):

No. 10 Screw Shear Capacity (Section E4.3):

#### Connection Shear Limited by Tilting and Bearing (Section E4.3.1):

$t_1 = 0.0566$ in	54 mil (Base Metal Thickness)
$t_2 = 0.0346$ in	33 mil (Base Metal Thickness)
$d = 0.190$ in	No. 10 Screw per Table C-E4-1
$F_{u1} = 65$ ksi	50 ksi Steel
$F_{u2} = 45$ ksi	33 ksi Steel
$\frac{t_2}{t_1} = 0.756$	

$P_{ns}$  for  $t_2/t_1 = 1.0$ :

$$P_{ns} = 4.2\sqrt{t_2^3 d F_{u2}} = 4.2\sqrt{(0.0346)^3 (0.190)(45)} = 0.530 \text{ kips} \quad \text{Eq. E4.3.1-1}$$

$$P_{ns} = 2.7t_1 d F_{u1} = 2.7(0.0566)(0.190)(65) = 1.887 \text{ kips} \quad \text{Eq. E4.3.1-2}$$

$$P_{ns} = 2.7t_2 d F_{u2} = 2.7(0.0346)(0.190)(45) = 0.799 \text{ kips} \quad \text{Eq. E4.3.1-3}$$

Therefore, nominal shear strength,  $P_{ns} = 0.530$  kips

#### Connection Shear Limited by End Distance (Section E4.3.2):

Assume end distance  $\geq 1.5d = 1.5(0.190 \text{ in}) = 0.285$  in

$$P_n = t_1 e F_{u1} = (0.0566)(0.285)(65) = 1.049 \text{ kips} \quad \text{Eq. E4.3.2-1}$$

$P_n > P_{ns}$ , Therefore the shear capacity will not be limited by end distance.

Shear in Screws (Section E4.3.3):

Assume shear capacity of screw exceeds tilting/bearing capacity of 33 mil material

Therefore,  $P_{ns} = 518$  kips

**Determine Required Number of Screws:**

$$\phi P_{ns} \geq P_u$$

$$\phi = 0.50$$

Section E4

$$\text{Number of screws, } n = \frac{P_u}{\phi P_n} = \frac{5.063 \text{ kips} \cdot \frac{1}{2}}{0.5(0.530 \text{ kips})} = 9.5$$

**Therefore, use 10-#10 screws each end of holdown straps to hip member and wall stud.**



**American Iron and Steel Institute**

1140 Connecticut Avenue, NW  
Suite 705  
Washington, DC 20036  
[www.steel.org](http://www.steel.org)



**Steel Framing Alliance™**

*Steel. The Better Builder.*

1201 15<sup>th</sup> Street, NW  
Suite 320  
Washington, DC 20005  
[www.steel framing.org](http://www.steel framing.org)

